



24"WIDE	Qty	30"WIDE	Qty	36"WIDE	Qty
SNB01		SNB07		SNB13	
SNB02		SNB08		SNB14	
SNB03		SNB09		SNB15	
SNB04		SNB10		SNB16	
SNB04A		SNB10A		SNB16A	
SNB05		SNB11		SNB17	
SNB05A		SNB11A		SNB17A	
SNB06		SNB12		SNB18	

FEATURES:

- * 1 3/4" Thick Hard Rock Maple Top
top style "SC" flat top
- * Maple top is finished with penetrating oil
with optional natural clear Varnique Finish
- * Stainless Steel Base and Bracing
Type 300 stainless steel with # 3 polish, satin finish
- * Bracing adjustable to desired height
- * Adjustable bullet feet
- * Shipped knocked-down, easy - to - assemble
- * Optional drawers, casters, pot racks, etc. available
- * All models are approved by the National Sanitation Foundation

MATERIAL:

- Top: Laminated Hard Rock Maple
- Bracing: 1 1/4" Round O.D. 18 gauge type 300 tubular stainless steel
3 polish, satin finish
- Legs: 1 5/8" Round O.D., 16 gauge type 300 tubular stainless steel
3 polish, satin finish
- Gussets: Stainless Steel
- Feet: 1" adjustable stainless steel bullet feet

OPTIONAL ACCESSORIES

	MODEL #	Qty
STAINLESS STEEL FEET		
DRAWER		
DRAWER LOCK		
CASTERS		
OVERSHELVES		
POT RACK		

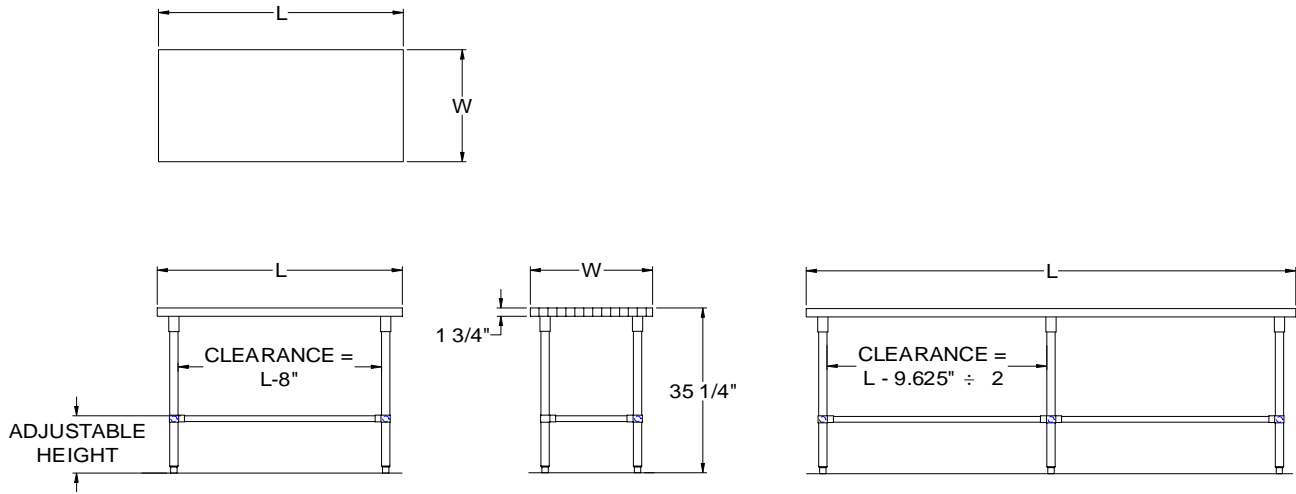

All units ship unassembled for reduced shipping cost.

Units 7 ft. and larger are furnished with six legs.

All dimensions are typical.

1-3/4" MAPLE TOP & STAINLESS STEEL BASE

Tolerance +/- .500".

L	24" WIDE	WT.	30" WIDE	WT.	36" WIDE	WT.
36	SNB01	65	SNB07	77	SNB13	88
48	SNB02	80	SNB08	95	SNB14	110
60	SNB03	95	SNB09	114	SNB15	133
72	SNB04	110	SNB10	133	SNB16	155
84	SNB04A	130	SNB10A	156	SNB16A	182
96	SNB05	150	SNB11	179	SNB17	209
108	SNB05A	165	SNB11A	198	SNB17A	231
120	SNB06	180	SNB12	217	SNB18	253



John Boos is constantly engaged in a program of improving products and therefore reserves the right to change specification without prior notice

March 2009