

KSS-521

FEATURES:

- * Sink Size: 27 1/4" x 20 1/2" x 8"
- * Material: 304 Stainless Steel, 19 Gauge
- * Chrome Nickel Content 18/10
- * Double Basin Topmount Sink
- * With Undercoating and Padding
- * Recommended Drain DS-005 Provided
- * Warranty: Limited Lifetime Warranty

CODES / STANDARDS APPLICABLE

- * CSA B45
- * ASME A112.19.2

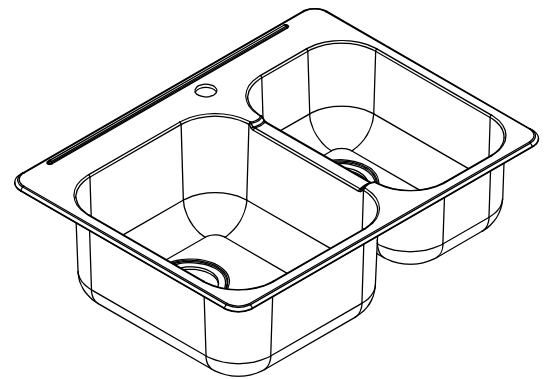
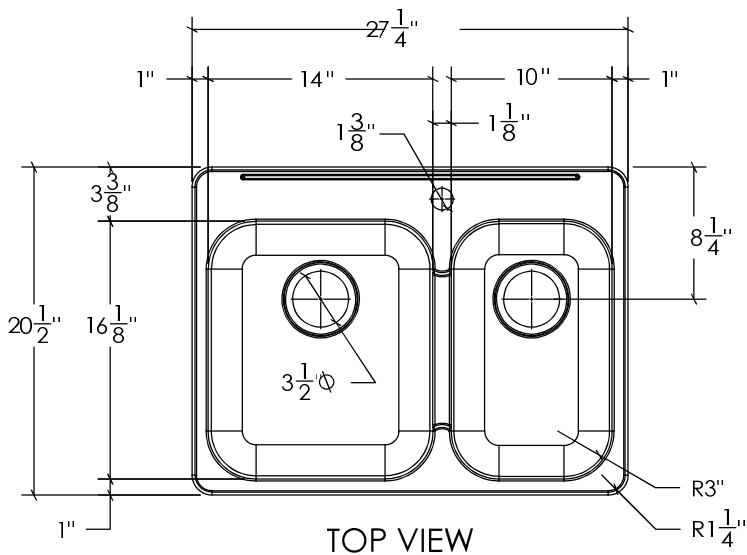

3D VIEW

