

Revolving Corner Unit Systems - Full Round



Corner floor unit revolving systems with circular revolving shelves

- for cabinets with front-mounted diagonal doors
- fixed center post
- shelves turn independently

Center post, vertically adjustable from 725 mm (28½") to 765 mm (30⅛")

With upper and lower bearings and height adjustment bearing. Capable of accommodating 3 shelves.

Finish:

Post: steel, chrome-plated

Height adjustment bearing: steel, galvanized

Upper bearing: plastic, white

Cat. No.	541.17.234
----------	------------

Packing: 1 pc.



Circular revolving shelf with wire fence

Complete with support and positioning device.

For cabinets 900 x 900 mm

Dimensions: Ø 750 mm (29 ½"), 80 mm (3 ⅛") high

Finish: steel, chrome-plated

Cat. No.	541.12.239
----------	------------

Packing: 1 pc.

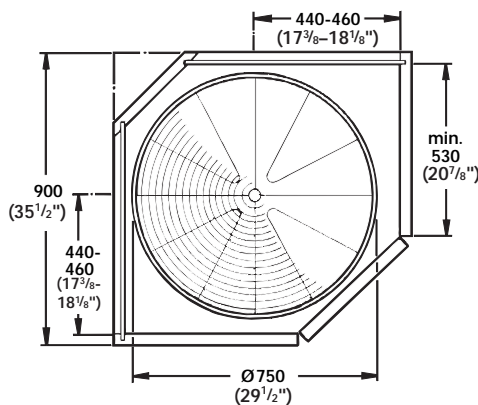

Round Revolving Shelf, ARENA Plus

Complete with support. With non-slip surface.

For cabinets 900 x 900 mm

Dimensions: Ø 750 mm (29 ½"), 80 mm (3 ⅛") high

Finish: white melamine shelf with steel, chrome-plated surround



Cat. No.	542.32.292
----------	------------

Packing: 1 pc.

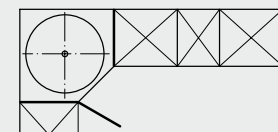
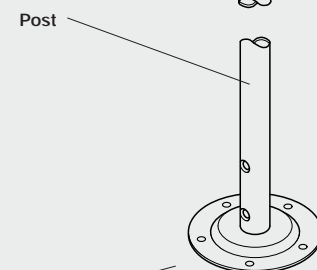
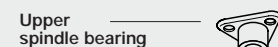
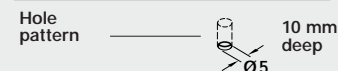

Organizational Products for Kitchen, Bath, Closet and Home Entertainment

- ARENA is the result of a manufacturing technology that seals melamine material with a polished chrome surround.
- The ARENA Plus non-slip surface prevents stored items from sliding.