

# PANTRY ROLL-OUT

## Installation Instructions

*Inspect all parts and read all instructions prior to beginning assembly and installation.*

### Parts Included

- A. Pantry, Lower Section
- B. Pantry, Telescopic Upper Section
- C. 6 – #8 x 3/4" Truss Head Screws
- D. 3 – #8 x 1/2" Truss Head Screws

### Tools Required

- Phillips head screwdriver
- Drill with 1/16" (1.5mm) bit for drilling pilot holes
- Tape measure or ruler
- Pencil

**Step 1** Slide the telescopic upper section of the pantry into the top of the lower section. **NOTE:** for frameless cabinet installation, the locator tab on the front mounting flange of the top slide will need to be flattened. In addition, the rear socket should be removed and the slide should be attached directly to the cabinet.

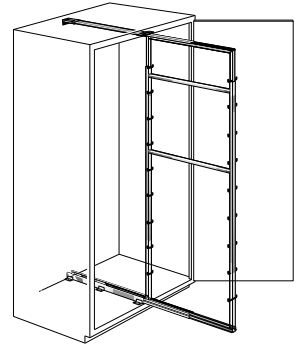

step 1

**Step 2** To correctly place the unit in the cabinet, place assembled unit in the cabinet opening and hang baskets on both sides. Then, slide unit in and out of cabinet to make sure it can clear opening and operate correctly. Adjust the telescopic upper section so that the front mounting flange on the top slide is flush with the bottom of the face frame or cabinet shelf.

**NOTE:** if inset or lip door is used, clearance allowances will need to be made for top and bottom slides.

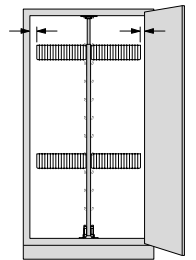

**Step 3** Mark the position for holes using the slots in the bottom slide. Also mark screw holes for the top slide's mounting flange. Adjust the top slide's rear socket depth by sliding the socket until it is flush with the back wall of the cabinet and mark holes. Drill pilot holes using previous marks. Use 1/2" screws to fasten unit to cabinet floor. Use 3/4" screws to fasten front mounting flange and rear socket to cabinet.

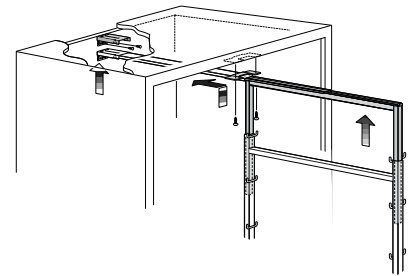

step 2

**Step 4** If necessary, plumb the unit vertically by loosening the screws in the slots of the bottom slide. Check action for vertical and front-to-back alignment by sliding the installed unit in and out of the cabinet to make sure it clears the opening. Adjust as necessary. Mount the baskets on the pantry's hooks to complete installation.

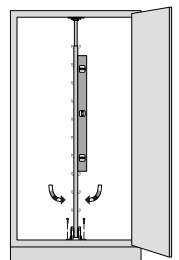

step 3



**Real Solutions**  
For Real Life.™