



an **SefaCo.** Store
1-877-275-9111

The Modular Rack for Fine Wine Care

Modular Wine Racks allow complete flexibility in assembly. Build a J. K. Adams rack up or out. Let it grow with your wine collection.

Make neat racks for handy access to a few favorite wines...

- ...in the kitchen
- ...at the bar
- ...in the pantry

Place in hard to use corners...

- ...on a counter
- ...over the refrigerator
- ...over, under or in cupboards

Fit odd shaped spaces making use of every last inch...

- ...in closets
- ...under stairways
- ...in cabinets

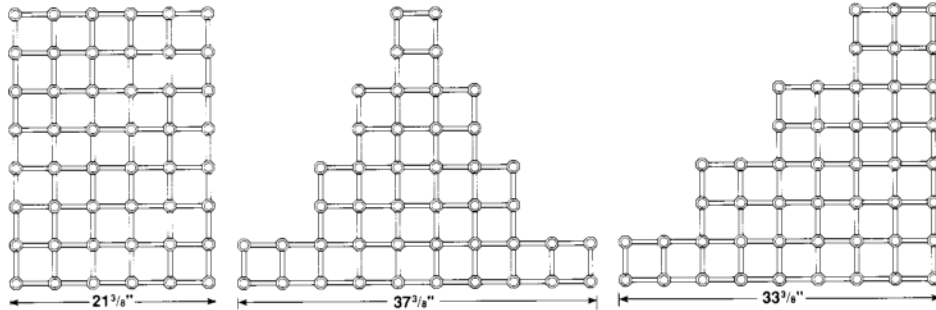
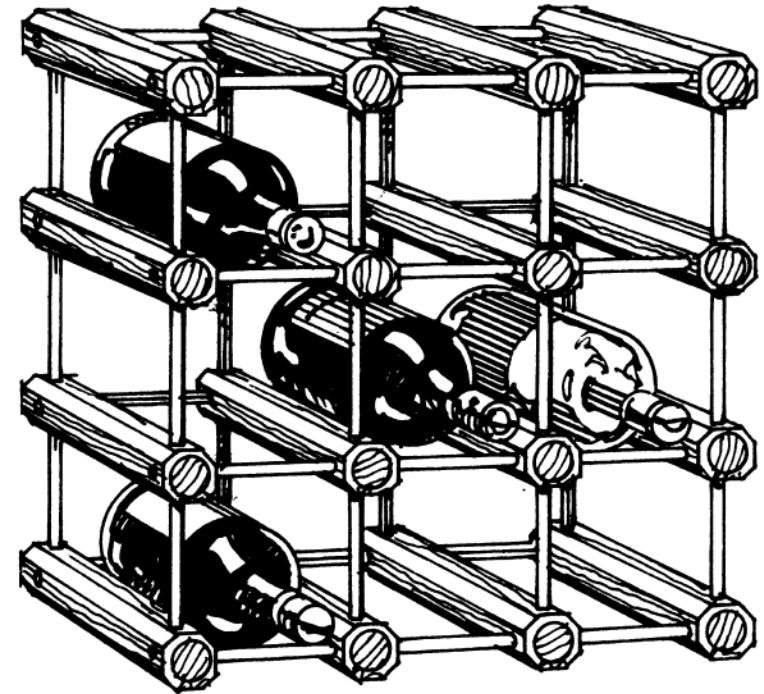
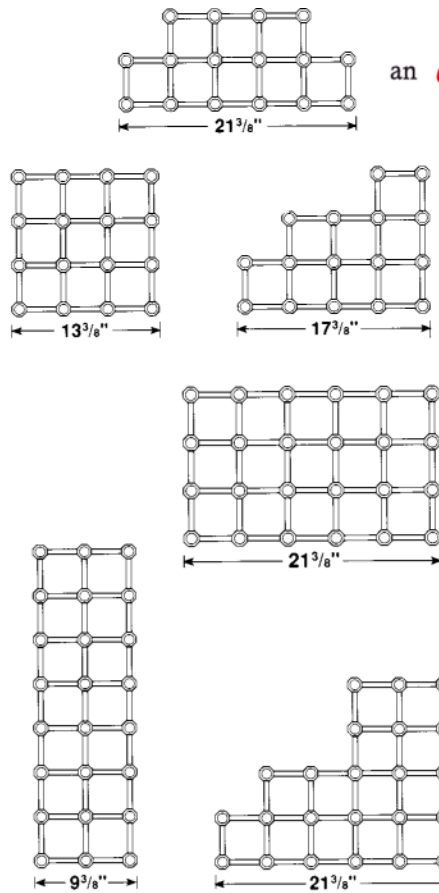

PLANNING GUIDE

Each cell of the assembled wine rack is 4" square. The octibeams are 1 3/8" in width. Therefore, the width or height of any rack may be calculated by multiplying the number of cells by 4" and adding 1 3/8".

The length of the beam is 11".

THE BUILDER'S PACKS

Model	Capacity*	Beams	Pins
MWR-6	6 Bottles	9	30
MWR-B12 wood	12 Bottles	16	56
MWR-B12 steel	12 Bottles	16	48
MWR-40	40 Bottles	48	180

*Capacity shown is for the simple rectangular shape. Actual capacity may be more or less with other configurations.

Assembly Instructions and Planning Guide



J.K. Adams Co.
DORSET, VERMONT

ASSEMBLY INSTRUCTIONS

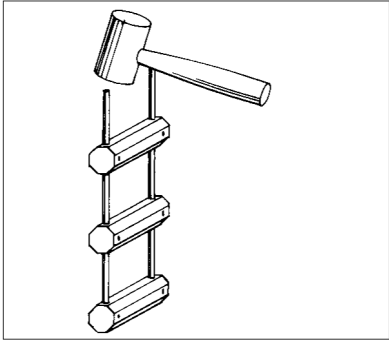

1. Assemble horizontal courses first. Drive in the pins until fully seated. Steel pins are more difficult to drive. Do not be afraid to pound on them with a hammer.

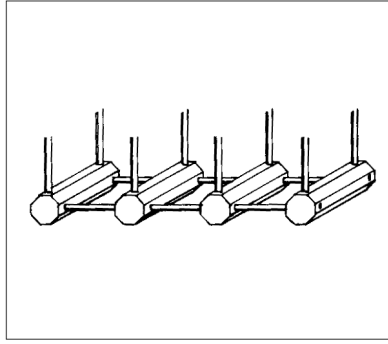

2. Add the vertical pins. If any wood pin seems loose, discard it and replace it with one of the spares.

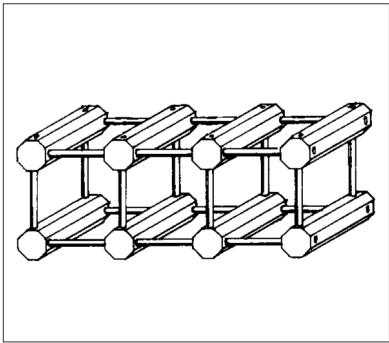

3. Join the courses, driving the frame tight as you proceed.

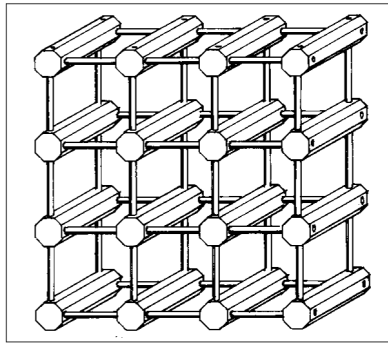

4. Pound tight and square to fully seat all the pins.

The Octibeam® is the key to the Modular Wine Rack's versatility. Each piece is cut from selected kiln hardwood, then shaped and drilled to precise tolerances on specially developed machinery. The beams assemble easily and securely, sit flat and will not roll as the pins are driven home.

Extra wooden pins are included for spares and for joining additional units when you wish to expand.

Glue is usually unnecessary on wine racks with wooden pins. Our pins are slightly oversized to produce a friction fit which is generally sufficient to insure a tight rack. In a dry environment, however, some wood joints may loosen. If this occurs add a spot of glue. Steel pins are shaped to grip and hold once they are pounded in place and therefore glue is never needed on them.

BUILDING LARGE WINE RACKS

Before beginning to assemble a large rack, be sure to measure the space and plan your layout carefully. Wine racks with steel pins cannot be disassembled and reconfigured. See the back page for planning suggestions.

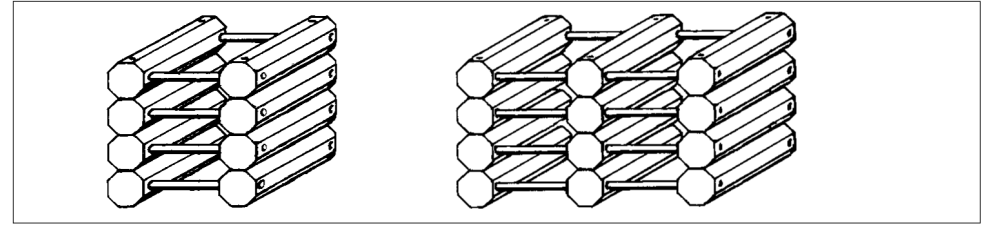

↑ 1. Long single beam courses tend to be difficult to handle. Start by sub-assembling two or three beam segments.

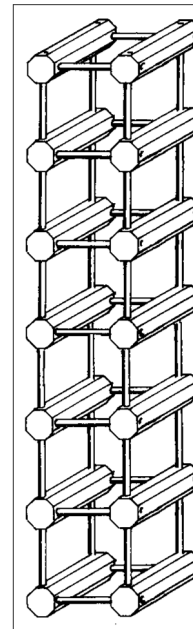

← 2. Join the segments to make double (or triple) beam horizontal courses of the required size. If the all wood rack will be very large, you may want to glue. See below.

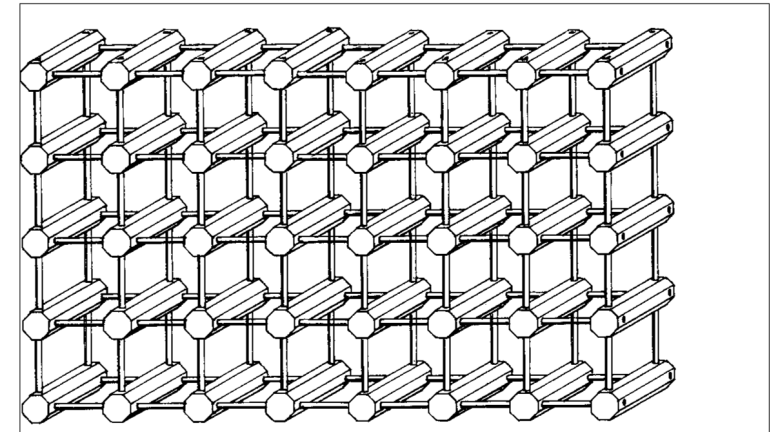

↑ 3. Now, join the double (or triple) courses, pounding tight as you go.

How To Use Glue for Large Racks

To maximize the stability of a large wine rack with wooden pins, you may wish to add glue to the horizontal pins when initially assembling. There is no gain in using glue with the vertical pins since gravity pulls it together at those joints.

In order to be sure that glue is applied at the sides of the hole where it is needed, follow this procedure: (1) Using a pair of common pliers, pinch ends of the dowel with the coarse grippers, pressing small channels into the wood to permit passage of glue up the sides of the dowel. (2) Squeeze a small amount of glue in the bottom of the hole. (3) Pound in the dowel until fully seated. Small beads of glue appearing at the edge of the hole will confirm that you have a good joint.