

WINDSTER™

User's Manual

R-18L36SS

R-18L42SS

ISLAND SERIES

NOTE: This unit was designed for indoor residential use only.

DO NOT USE OVER A WOOD GRILL OR MOUNT IN OUTDOOR ENVIRONMENT.



Please read this operation manual thoroughly before using your range hood. Store it in a safe location for when you need to reference it in the future.

2

SAFETY INFORMATION

SAFETY INFORMATION



TO REDUCE THE RISK OF A FIRE, ELECTRICAL SHOCK, AND/OR INJURY OBSERVE THE FOLLOWING:

- Unit is intended for indoor residential use only. If you should have questions, contact the manufacturer at the address or telephone number listed in the warranty.
- In case the unit should need to be cleaned or repaired, switch power off at service panel and lock service disconnecting means to prevent power from being switched on accidentally. When the service disconnecting means cannot be locked, securely fasten a prominent warning device, such as a tag, to the service panel.
- Installation work and electrical wiring must be done by a qualified technician in accordance with all applicable codes and standards, including fire-rated construction.
- Sufficient air is needed for proper combustion and exhausting of gases through the flue (chimney) of fuel burning equipment to prevent back drafting. Follow the heating equipment manufacturer's guideline and safety standards such as those published by the National Fire Protection Association (NFPA), and the American Society of Heating, Refrigeration and Air Conditioning Engineers (ASHRAE), and the local code authorities.
- Because the unit is made of stainless steel, it may contain sharp edges. Be careful to avoid cuts and abrasions by wearing protective gloves during installation and cleaning.
- Before you begin to cut or drill into the wall, verify that there is no electrical wiring or any other hidden electrical components.
- Ducted fans must always be vented to the outdoors.
- The unit must be properly grounded and installed at the recommended height before beginning operation.
- To reduce the risk of fire, use only metal ductwork.



CAUTION: FOR GENERAL VENTILATING USE ONLY. DO NOT USE TO EXHAUST HAZARDOUS OR EXPLOSIVE MATERIALS AND VAPOR

SAFETY INFORMATION **3**

 **TO REDUCE THE RISK OF FIRE, OR ELECTRIC SHOCK, DO NOT USE THIS FAN WITH ANY SOLID-STATE SPEED CONTROL DEVICE.**

- Regardless of heat level, never leave any surface materials unattended while operating an open flame.
- Always turn hood ON when cooking at high heat or when flambéing food (i.e. Crepes Suzette, Cherries Jubilee, Peppercorn Beef Flambé).
- Depending on amount of usage, clean ventilating fans and filters frequently. Grease should not be allowed to accumulate on fan or filter. For instructions on the how to clean, see maintenance page.
- Never leave surface units unattended at high settings. Boil-overs may cause smoking and greasy spillovers may ignite as result. Heat oils slowly on low or medium settings.
- Use proper pan size. Always use cookware appropriate for the size of the surface element.

 **TO REDUCE THE RISK OF INJURY TO PERSONS IN THE EVENT OF A RANGE TOP GREASE FIRE, OBSERVE THE FOLLOWING:**

- SMOTHER FLAMES with a close-fitting lid, cookie sheet, or metal tray, then turn off the burner. BE CAREFUL TO PREVENT BURNS. If the flames do not go out immediately, EVACUATE AND CALL 911.
 - NEVER PICK UP A FLAMING PAN —Doing so may result in serious burns and possibly spread the fire.
 - DO NOT USE WATER – Grease fire must be extinguished before further action may be taken. Using water will agitate the grease and may cause a violent steam explosion.
 - Use a Fire Extinguisher ONLY if:
 - ❖ You know you have a Class ABC extinguisher, and you already know how to operate it.
 - ❖ The fire is small and contained in the area where it started.
 - ❖ The fire department is being called.
 - ❖ You are able to safely control the fire with your back to an open exit. *
- * Based on "Kitchen Fire safety Tips" published by NFPA.

4**CONTENT CHECKLIST****CONTENT CHECKLIST****1. CONTENTS INCLUDED**

- a. (1) R-18L series(36" or 42")hood assembly
- b. (1) Lower duct cover (18-1/8")
- c. (1) upper duct cover (19-1/4")
- d. (1) User's manual
- e. (1) 6" – 7" transition collar
- f. (2) Oil cup filters
- g. (1) Screw packet

2. CONTENTS NOT INCLUDED

- a. R-18LSDC (Short duct cover)
- b. R-18LLDC (Long duct cover)
- c. R-18LMF (Mesh filter)
- d. R-18LDK (Ductless kit)
- e. R-18LCF (Charcoal filter)
- f. R-18LCFMR (CFM reducer)
- g. 6" / 7" Aluminum or metal piping

3. TOOLS REQUIRED (NOT INCLUDED)

- a. Safety gloves
- b. Safety glasses
- c. Electric drill w/ starter bit
- d. Utility knife
- e. Spirit level
- f. Measuring tape
- g. Writing instrument (pen, marker, pencil)
- h. Aluminum tape

MEASUREMENTS

5

Fig. 1a

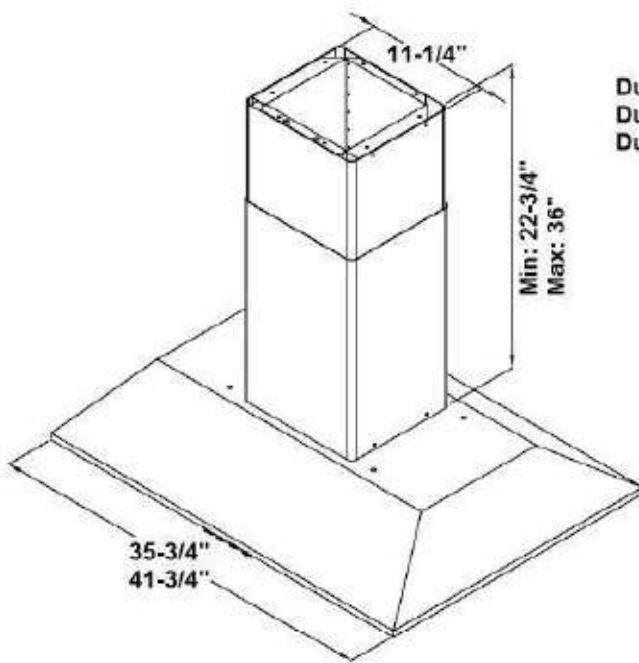

▼ Side

Ductless operation
Duct cover min: 29"
Duct cover max: 36"

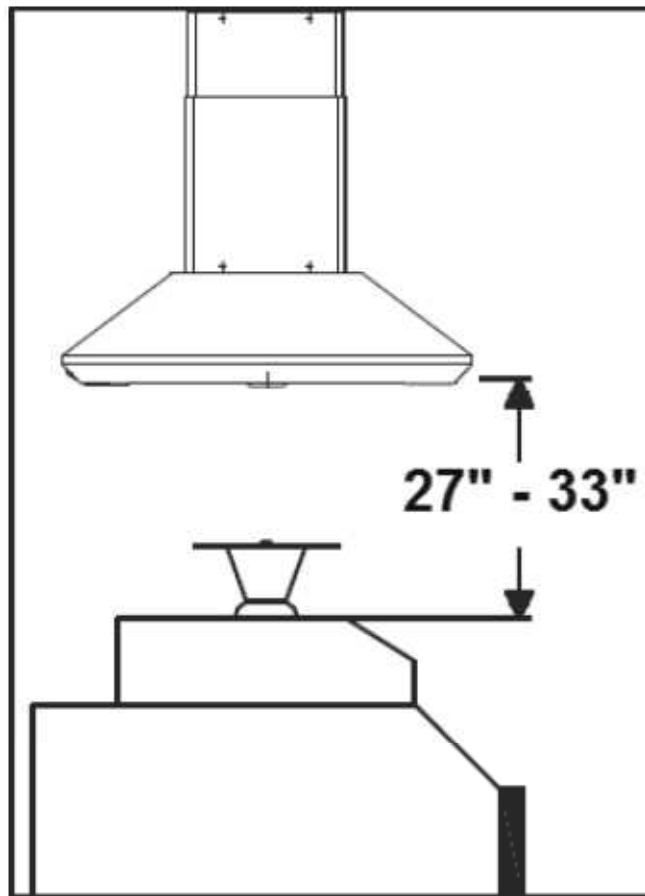
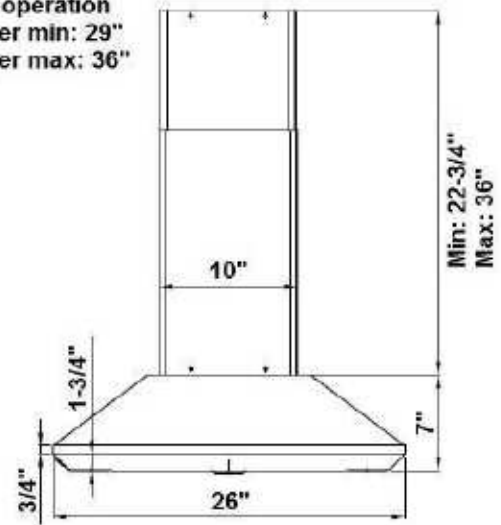

6

PREPARATION

PREPARATION

1. BEFORE YOU START

****BE SURE YOUR UNIT WILL FIT YOUR CEILING HEIGHT****

- a. Be sure you have all the content of your purchase and required tools for this installation.
- b. Installation may take at least 2 to 3 hours from start to finish.
- c. Plan to use as few elbows or turns as possible for more efficient air flow.
- d. Collar size may need to be increased if utilizing a long duct run.
- e. Turns must be made after passing ceiling.
- f. Do not try to install this unit by yourself, **SERIOUS INJURY MAY OCCUR.**
- g. At least two people are needed for installation.
- h. Hiring a certified installer and electrician is recommended.

2. LOCATION

****THIS MODEL MAY NOT FIT ALL CEILING HEIGHTS****

- a. Determine the exact location you where want to install the range hood.
- b. Distance between cooktop and range hood should be between 27"-33".
- c. Range hood should be mounted at stated measurements to ensure performance and lifespan of electrical components.
- d. Correctly measure the dimension needed to install the unit.

3. HOOD

- a. Inspect for any sign of defect or damage. (ie. scratches, dents, loose seams, etc.)
- b. Power up the unit to make sure it is working properly.
- c. Remove the protective file on the aluminum filters.

Use Fig. 1a on page 5 for unit measurements

INSTALLATION

1. STANDARD INSTALLATION

- a. Make sure all preparation steps are completed.
- b. Determine your ceiling height to see if you need an extension.
 - i. Hood unit height = **7"**
 - ii. Standard DC height = **18-1/8"** (lower) + **19-1/4"** (upper)
 - iii. Minimum height (Standard duct cover only) = **22-3/4"**
 - iv. Maximum height (Standard duct cover only) = **35"**
 - v. (OPTIONAL) Short DC minimum height = **16"**
 - vi. (OPTIONAL) Short DC maximum height = **16"**
 - vii. (OPTIONAL) Long Ext DC Minimum height = **33-1/2"**
 - viii. (OPTIONAL) Long Ext DC Maximum height = **58"**
 - ix. **Standard Installation = Hood + standard DC**
 - x. **Short Installation = Hood + short DC**
 - xi. **Long Installation = Hood + long Ext DC**
- c. Determine the location you want to install the range hood.
- d. Prepare ceiling and locate wood support.
- e. Use stencil to guide the support frame installation.
- f. Mount the unit upper support frame to the ceiling. **(Fig. 2a)**
- g. Cut a 6" or 7" round opening at the ceiling for ducting pipe.
- h. Insert upper duct cover to the lower support frame.
- i. Insert both support frame and duct cover to the upper support frame.
- j. Adjust the lower support frame to your desired height. **(Fig. 2b)**
- k. Use a spirit level to ensure the balance of the support frame is true.
- l. Slide upper duct cover toward ceiling and secure it to support frame.
- m. Install ducting through the ceiling.
- n. Adjust duct cover to accommodate the support frame. **(Fig. 2c)**
- o. Slide the lower duct cover up to the upper duct cover and hold in place.
- p. Secure the hood from the top by using the (8) screws provided. **(Fig. 2d)**
- q. Connect piping to the outlet of the hood.
- r. Installation is complete when hood is securely in place. **(Fig. 2f)**

8**INSTALLATION****2. EXTENSION / SHORT INSTALLATION (OPTIONAL)**

- a. **AFTER COMPLETING STEP A– E OF STANDARD INSTALLATION**, replace the standard support frame and duct cover with either the extension set or the short duct cover set.
- b. **REPEAT “STEP G – Q” from STANDARD INSTALLATION.**

3. COLD WEATHER INSTALLATION (OPTIONAL)

- a. Check with your local building codes to see if a CFM reducer is an acceptable alternative to make-up air.
- b. Remove the R-18LCFMR (CFM Reducer) and inspect for any sign of defect or damage. (ie. Cracks, broken flips)
- c. **AFTER COMPLETING Step A – L of STANDARD INSTALLATION**
- d. Place the CFM reducer onto the outlet of the unit and seal the connection point with aluminum tape. (Be sure it is secure with no opening or gaps)
- e. Connect piping to the outlet of the hood.
- f. Installation is complete when hood is securely in place.

4. DUCTLESS INSTALLATION (OPTIONAL)

- a. **AFTER COMPLETING Step A – F of STANDARD INSTALLATION**
- b. Remove the R-18LDK (ductless kit) and inspect for any sign of defect or damage. (ie. dents, broken inlet)
- c. Attach the ductless kit to the support frame and secure with screws.
- d. Install the upper duct cover and secure it to the support frame.
- e. Slide the lower duct cover up to the upper duct cover and hold in place.
- f. Connect a 6” or 7” pipe between the ductless kit and the hood outlet.
- g. **REPEAT “STEP J – N” from STANDARD INSTALLATION.**

Installation diagram available on next page

INSTALLATION DIAGRAM

INSTALLATION DIAGRAM

Fig. 2a

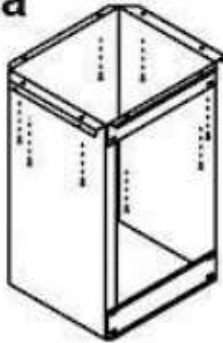

Fig. 2b

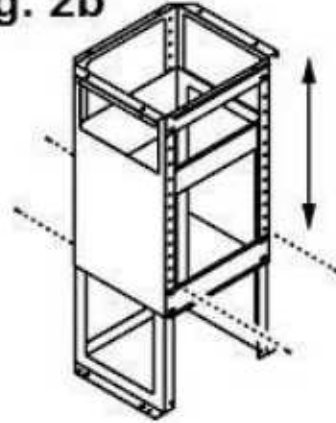

Fig. 2c

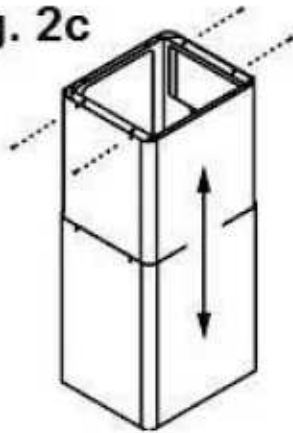
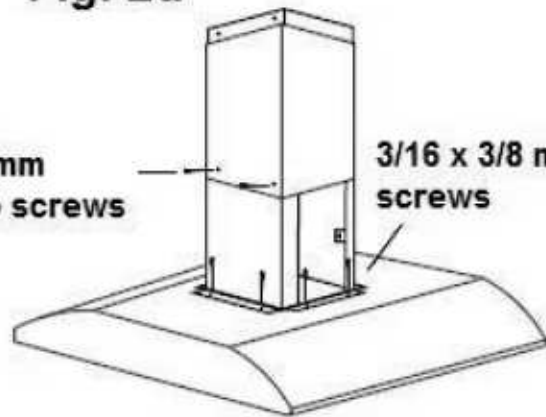

Fig. 2d

(4) 8mm
temp screws



3/16 x 3/8 mm
screws

Fig. 2e

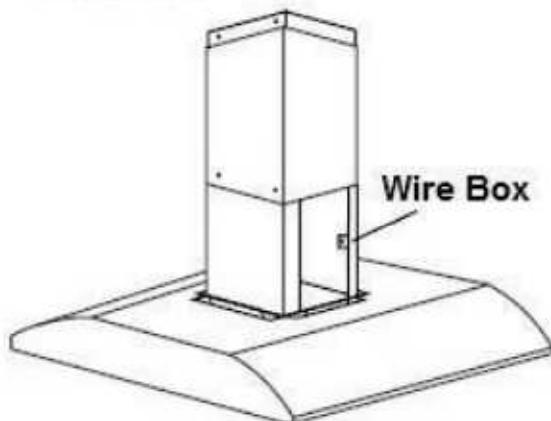

Wire Box

Fig. 2f

(4) 8mm
temp screws

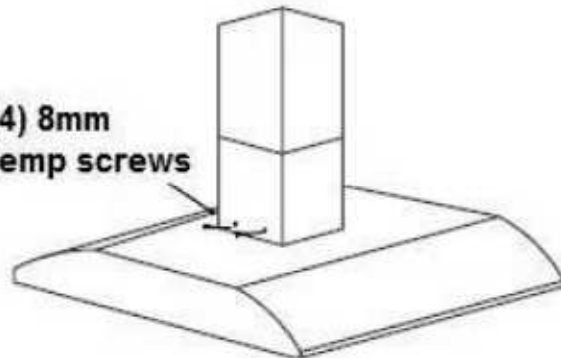

10 OPERATION & FEATURES

OPERATION & FEATURES

1. EASY ACCESS CONTROL SWITCH (from left to right)

- a. Button 1 – ON / OFF
- b. Button 2 – Light
- c. Button 3 – Speed

2. OIL CUP FILTERS

- a. (2) Round oil cup filters

3. INSTALLING THE CHARCOAL FILTERS

- a. Remove both grills at the bottom of the hood.
- b. Place the charcoal filters on the grills and screw into place .
- c. Insert the grills back into the hood along with the attached charcoal filter.
- d. Installation is complete after the charcoal filters are secured in place.

CLEANING & MAINTENANCE **11**

CLEANING & MAINTENANCE

WARNING!!!



To prevent the possibility of a fire and explosion, do not use flammable liquids or solvents to clean the unit or any of its parts.



Check to make sure all power sources are disconnected before servicing or taking unit apart for cleaning.

1. RANGE HOOD

- a. Use household cleaner to remove grease or dirt from the outer shell of the unit. Spray on wiping cloth or sponge and wipe in the direction of the grain to avoid scratching the unit. (DO NOT SPRAY DIRECTLY ONTO UNIT)
- b. Clean the inner working of the unit periodically to avoid grease build-up.
- c. Do not open control switch panel while the hood is connected to power.
- d. Use stainless steel cleaner to bring back the luster of the unit.

2. OIL CUP FILTERS

- a. Remove oil cups by turning counter-clockwise until cup detach.
- b. Properly dispose of all oil accumulated in the cup.
- c. Let cups soak in warm soapy water and wipe clean with sponge.
- d. Oil cups may also be cleaned using residential dishwasher.

3. CHARCOAL FILTERS

DO NOT WASH CHARCOAL FILTERS! IT WILL DISSOLVE!!

- a. When to replace a charcoal filter will depend on:
 - i. How often you cook.
 - ii. How long you cook.
 - iii. Types of food you cook.

12 TROUBLESHOOTING

TRUBLESHOOTING

WARNING!!!



Check to make sure all power sources are disconnected before starting any troubleshooting. Safety gloves and glasses should be worn when working on the unit. Serious injury or death may occur if safety precautions are not followed.

R-18L Series	
Light issue (All not turning on)	1. New Transformer/ Driver replacement is required.
Halogen/LED light issue	1. Halogen: Replace burnt 20w light bulb 2. LED: Replace defective fixture with new LED fixture.
Light issue (One light not turning on)	1. Replace defective light fixture with new light fixture.
Speed indicator not showing speed levels	1. Complete control switch replacement is required.
Burnt/melted control switch	1. Complete control switch replacement is required.
Speed levels not working correctly	1. Complete control switch replacement is required. 2. Complete Control Board replacement may be required.
Unit lacking smoke intake	1. Check ducting for foreign object. 2. Ensure the ducting is properly sealed. 3. Clean filters to increase airflow.
Unit showing no power indication	1. Make sure the power source is working properly. 2. Ensure all wiring is connected properly.
Unit making humming noise / motor not working	1. Replace defective capacitor with new one. 2. Check / replace defective motor.

PART LIST / REPLACEMENT **13**

PART LIST / REPLACEMENT

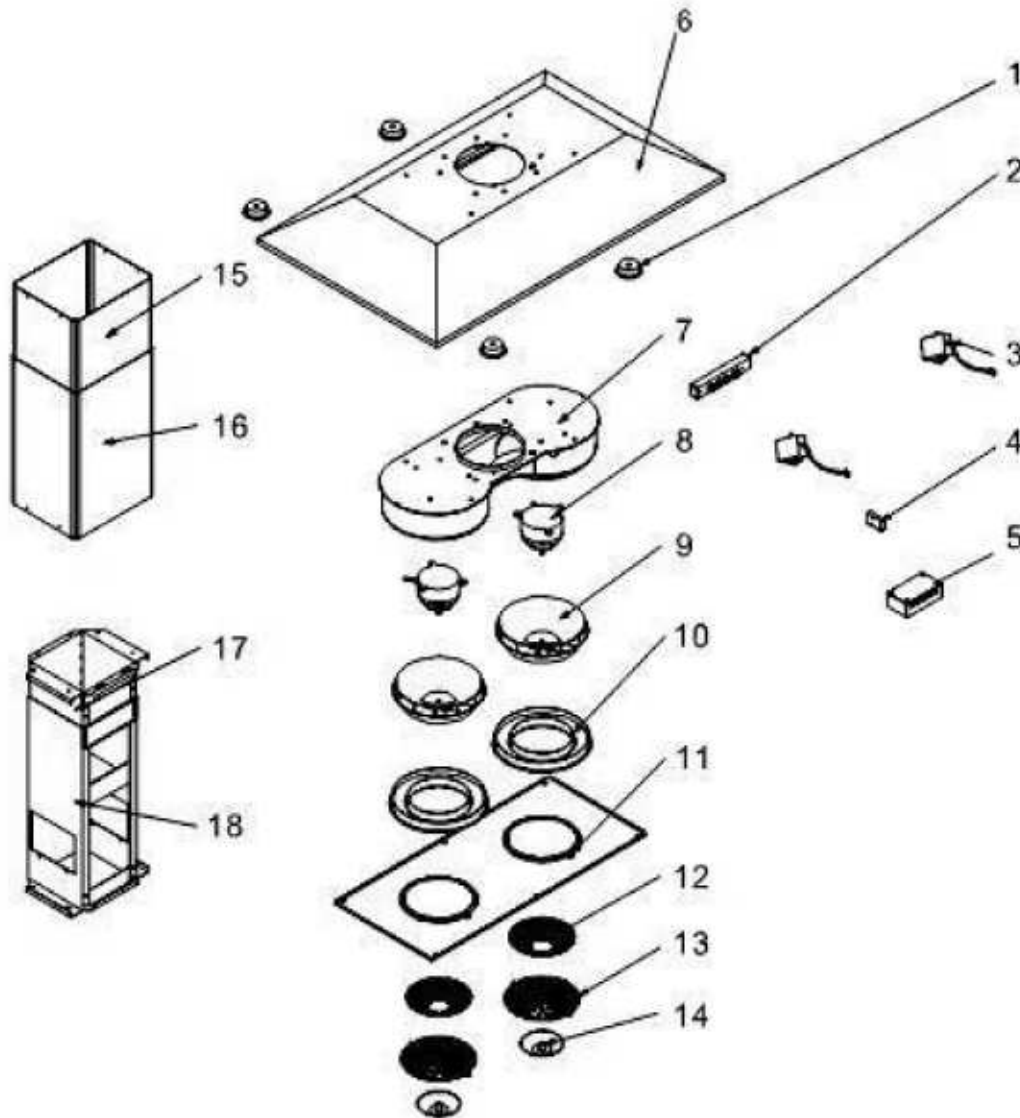

1	LED light	8	Motor	15	Inner chimney duct cover
2	Control board	9	Turbine impeller	16	Outer chimney duct cover
3	LED transformer	10	Oil tunnel	17	Inner telescopic stack
4	Capacitor	11	Bottom panel	18	Outer telescopic stack
5	Motherboard	12	Mesh filter		
6	Hood body	13	Grill		
7	Chamber	14	Oil cup		