

Purescape 503™

Freestanding Stone Bathtub

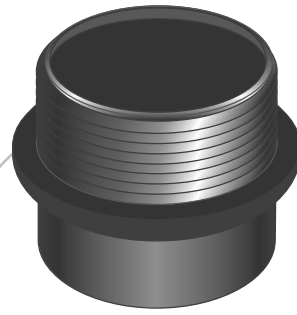
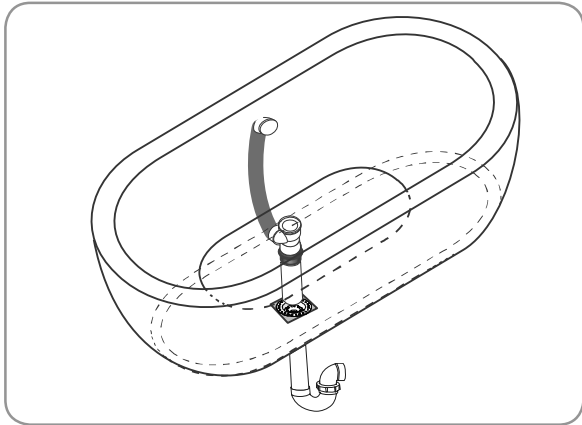

★ Use Male Adapter Spg x MIPT - ABS DWV for Aquatica bath wastes with Sch40 Waste Fitting Thread 1½ NPSM (1½ IPS)

Sch40 Waste Fitting

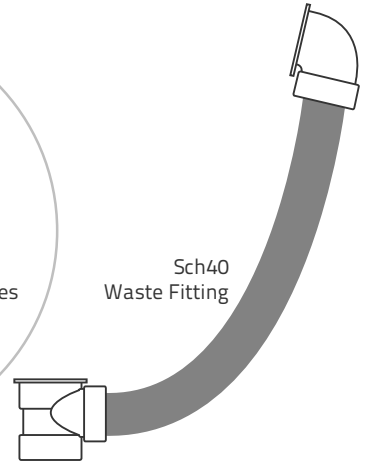

Aquatica® Freestanding Bath Installer™ (not supplied)

★ 1½" flanged brass tube for Aquatica cable-drive and concealed bath wastes.

P-Trap (not supplied)

PLEASE NOTE: Parts marked with ★ are supplied as part of Aquatica® Freestanding Bath Installer™ Kit (NOT included with bathtub)

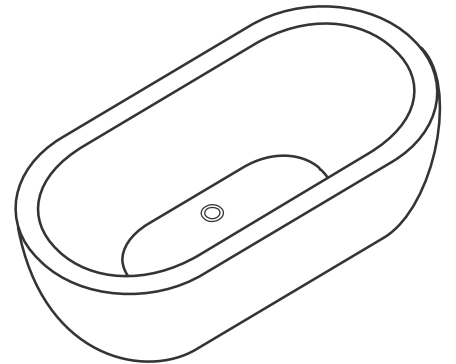
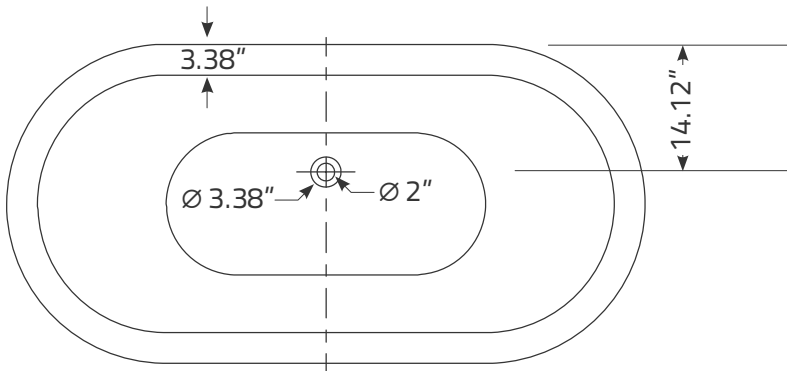
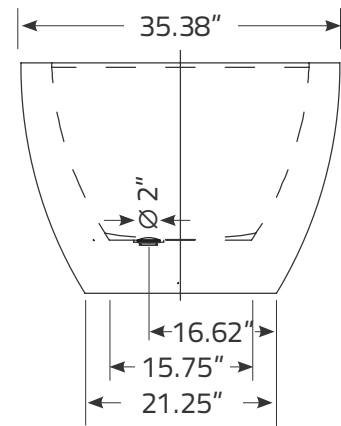
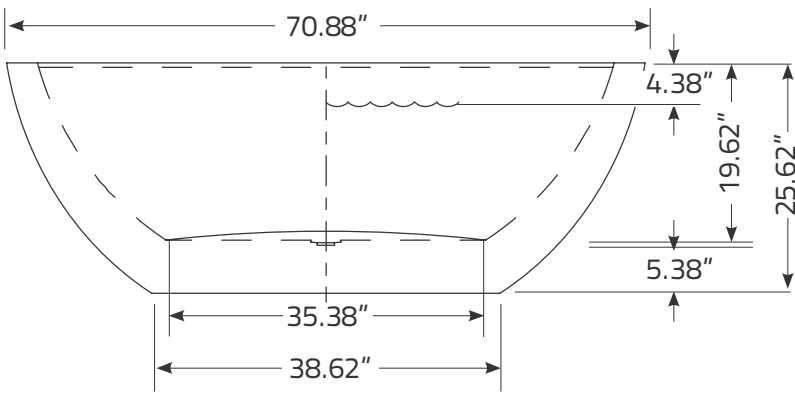

Purescape 503™

Freestanding Stone Bathtub

aquatica®
Function, Form & Fashion

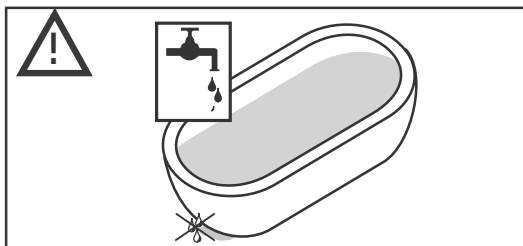
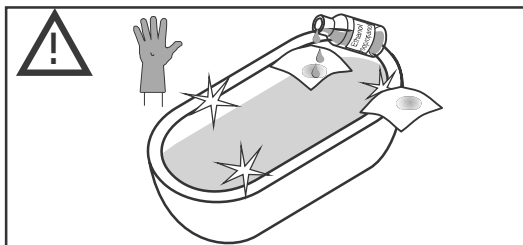
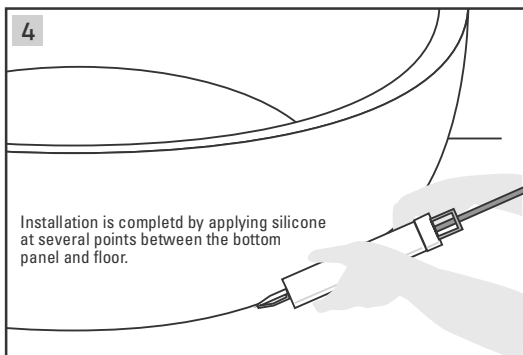
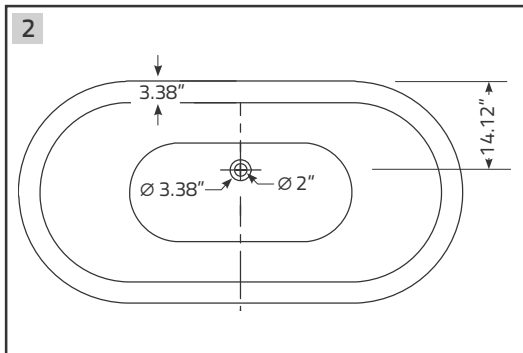
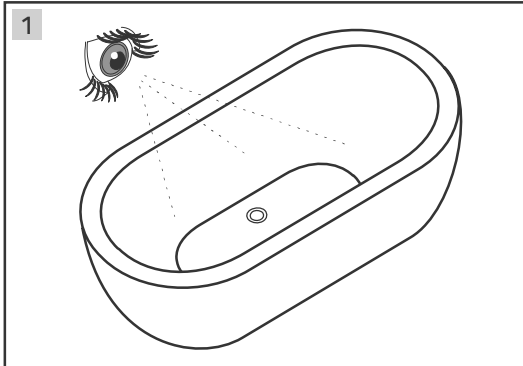

3 USA & CANADA INSTALL

Sch40 Waste Fitting

Male Adapter Spg x MIPT - ABS DWV - available for purchase separately

1 1/2" flanged brass tube - available for purchase separately

Aquatica® Freestanding Bath Installer™ in the floor - available for purchase separately

P-Trap - not included

HANDLE WITH CARE

DO NOT DROP

The Male Adapter Spg x MIPT - ABS DWV for Aquatica bath wastes with Sch40 Waste Fitting and Aquatica® Freestanding Bath Installer™ are not included with bathtub.

Aquatica® Freestanding Bath Installer™

(Kit available separately - not include with bathtub)

FEATURES

- 18 Gauge Epoxy coated Metal Deck Flange
- Designed to be installed in an 8" joist space
- Can be installed with Waterproofing Membrane (*bronte™ NobleSeal TS Recommended)
- CSA Certified for Canadian and US markets

KIT INCLUDES

- 2 Brass Tailpieces (Fine Thread and Flanged)
- Freestanding Bath Installer™ assembly with 1-1/2" DWV ABS tailpiece
- Cutting template

INSTALLATION TIPS

- Use 6.5" hole saw to cut sub floor (not included). Cutting template included
- Do not cut the brass Tailpiece as this may cause a leak
- Secure Deck Flange with 6 screws (not included)

Certification

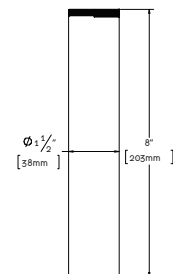
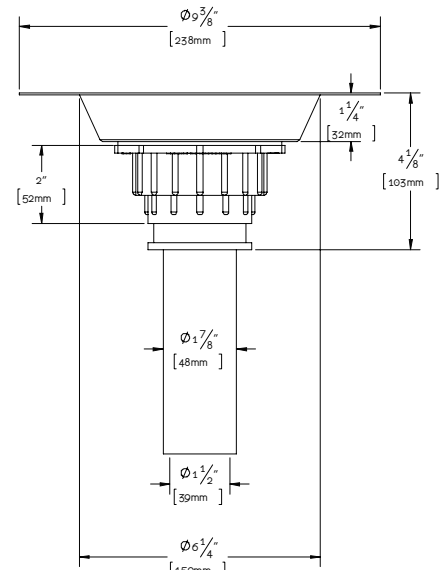

1 1/2" brass tube for female threaded stone bath wastes.

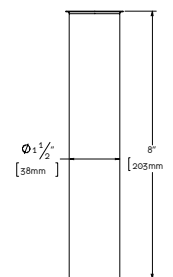

1 1/2" flanged brass tube for Aquatica cable-drive and concealed bath wastes.

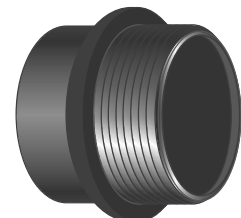

Male Adapter Spg x MIPT - ABS DWV for Aquatica bath wastes with Sch40 hub outlet.
Thread: 1 1/2" NPSM (1 1/2" IPS)

(Kit available separately - not include with bathtub)

INSTALLATION INSTRUCTIONS

Attaches to Freestanding Bath W/O

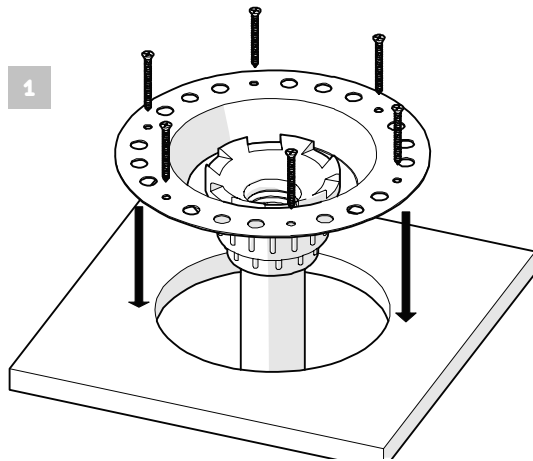

- 1
 - A. Cut 6-1/2" (16.5 cm) hole into wood sub-floor (use supplied Cutout Template).
 - B. Measure and cut ABS Tailpiece as necessary to ensure a secure connection to P-Trap below.
 - C. Insert Freestanding Bath Installer™ assembly into floor opening and connect to Pipe below.
 - D. Affix to sub-floor with 6 screws (not supplied)

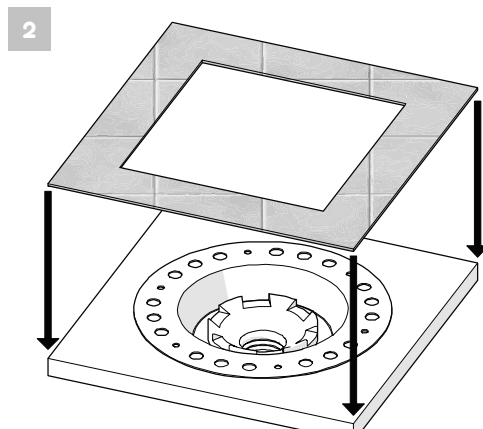

- 2
 - A. Install flooring surface, leaving a 6-1/2" opening to access Drain.
 - B. Affix the appropriate brass Tailpiece to the Waste & Overflow. **NOTE: DO NOT CUT THE BRASS TAILPIECE AS THIS MAY CAUSE A LEAK.** Ensure the measurement between the base of the Drain and P-Trap will accommodate the Tailpiece. Other lengths available from ??????????

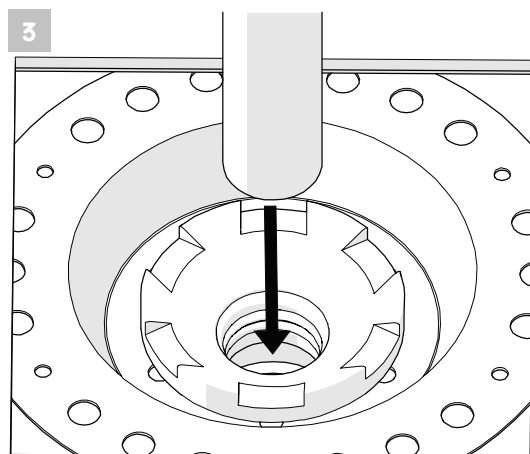

- 3
 - A. Cut out the Installation Label with a utility knife and remove to expose the Drain.
 - B. Apply lubricant (supplied) to the Tailpiece.
 - C. Position the Tub and brass Tailpiece in-line with the Drain.
 - D. Carefully lower the tub with the installed brass Tailpiece into the Red Collar in Drain assembly. Ensure Tailpiece is fully engaged with Seal.

IMPORTANT: Do not remove Installation Label until Step 3.

DO NOT CUT THE SUPPLIED BRASS TAILPIECE. Doing so may cause a leak.

Disassembling the drain or cutting the Tailpiece will void the warranty.

Purescape 503™ - Maintenance Instructions

Purescape 503™ - Инструкция по уходу

Purescape 503™ - Installation & Entretien

Purescape 503™ - Manuale per il corretto mantenimento

Purescape 503™ - Instrucciones para la correcta manutención

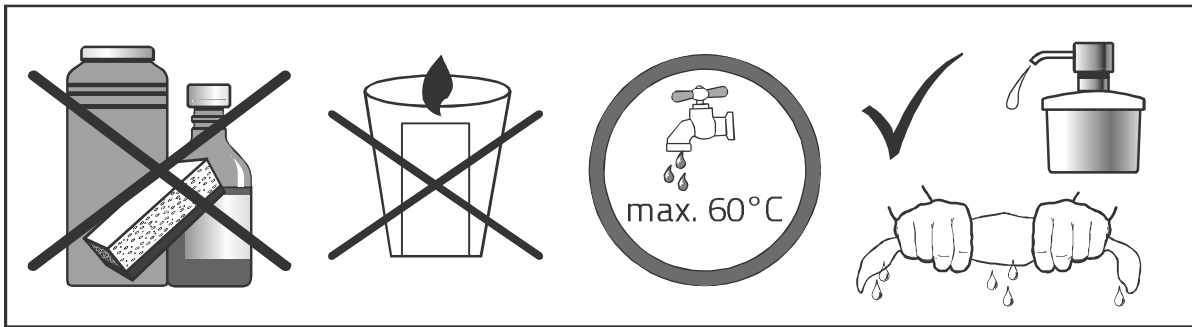

Maintenance Instructions

The smooth surface of your Aquatica® Aquastone™ Bathtub accumulates hardly any dirt, and can be maintained by simply cleaning with a soft cloth, using a mild detergent in water, then wiping over with a dry cloth.

Avoid using abrasive cleansers or solvents, which will cause damage to the surface. Damage caused by use of these products, or any other inappropriate treatment, is not covered by our guarantee.



Инструкция по уходу

Поверхность легко чистится. За счет гладкости грязь к ней не прилипает. Для регулярного ухода используйте мягкую ткань, мыльный раствор и воду. После чистки вытирайте поверхность сухой тканью, которая хорошо впитывает влагу.

Не используйте губки с абразивной поверхностью и агрессивные растворители, которые могут повредить ванну. Повреждения, возникшие вследствие неправильного ухода, не покрываются гарантией.



Installation & Entretien

Cette surface est facile à entretenir et à nettoyer. Sa surface particulièrement lisse, ne retiens que très peu la saleté. Un entretien quotidien nécessite simplement l'utilisation d'un chiffon doux, de l'eau et un peu de savon. Essuyer avec un chiffon sec. L'utilisation de détergents ou de solvants endommageraient cette surface.

Les dommages resultants d'un traitement non conforme effectué par l'utilisateur sont exclus de la garantie que nous offrons.



Manuale per il corretto mantenimento

La superficie necessita di pulizia ed accorgimenti per il corretto mantenimento. Una superficie liscia non accumula lo sporco. Usare una spugnetta con del detergente non aggressivo per una pulizia regolare. Asciugare con un panno. Evitare l'uso di solventi o materiali abrasivi: potrebbero rovinare la superficie.

Un danno causato da trattamento inappropriato non verrà coperto dalla garanzia.



Instrucciones para la correcta manutención

La superficie debe de ser limpiada y adecuadamente mantenida. Una superficie lisa no acumula suciedad.

Utilice una esponja con un detergente suave para la limpieza diaria. Seque con un paño.

No utilice disolventes o materiales abrasivos ya que podrían dañar la superficie.

Los daños causados por el tratamiento inadecuado no serán cubiertos por la garantía.