

Front View

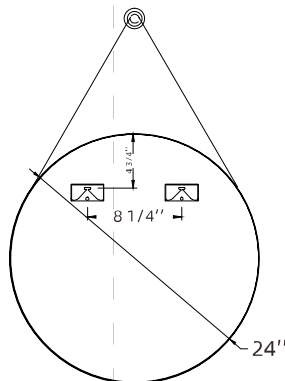

Back View

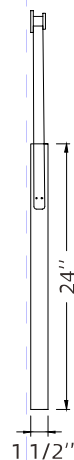

Side View

FEATURES

- 5mm Copper free mirror.
- PVC film backed.
- Mounting type: Vertically
- Energy Efficient and Long Lasting LED Lighting.
- 1Year Limited Warranty on Electronic Components.

LIGHTING:

- LED (Light-Emitting Diode).
- Defogger .
- Dimmable
- Color Temperature: 6000K .
- Power Source: Input: 110volts, 50/60HZ.
- IP44 rated.
- Brightness Lumen: 2800;
- Power Consumption :36Watts ;
- Energy saving LED lifetime approx 50,000 hours.
- UL certificated for electric power supply, defogger and LED strips.

Available Standard size:

24"x24"
30"x30"

Certification:



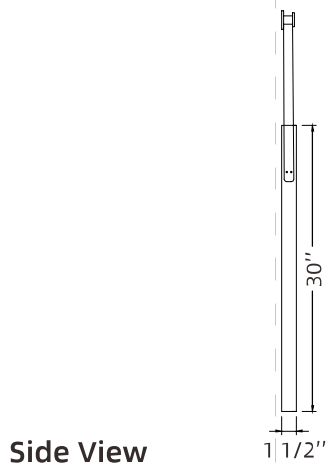
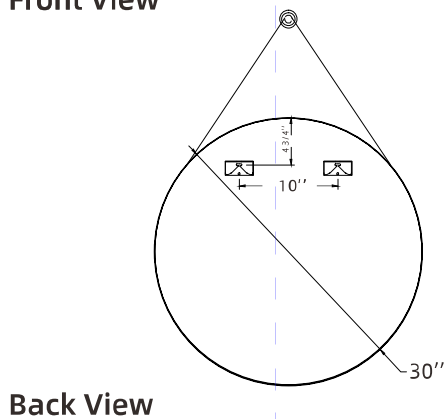
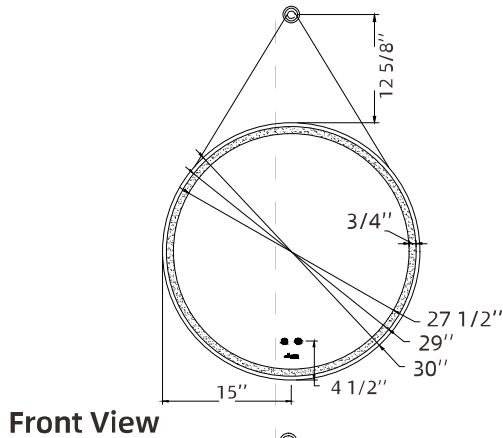

FEATURES

- 5mm Copper free mirror.
- PVC film backed.
- Mounting type: Vertically
- Energy Efficient and Long Lasting LED Lighting.
- 1Year Limited Warranty on Electronic Components.

LIGHTING:

- LED (Light-Emitting Diode).
- Defogger .
- Dimmable
- Color Temperature: 6000K .
- Power Source: Input: 110volts, 50/60HZ.
- IP44 rated.
- Brightness Lumen: 3280;
- Power Consumption :48Watts ;
- Energy saving LED lifetime approx 50,000 hours.
- UL certificated for electric power supply, defogger and LED strips.

Available Standard size:

24"x24"
30"x30"

Certification:

