

FVN1060
ATTRAZIONE
INSTALLATION GUIDE

kitchensource.com
 1.800.667.8721

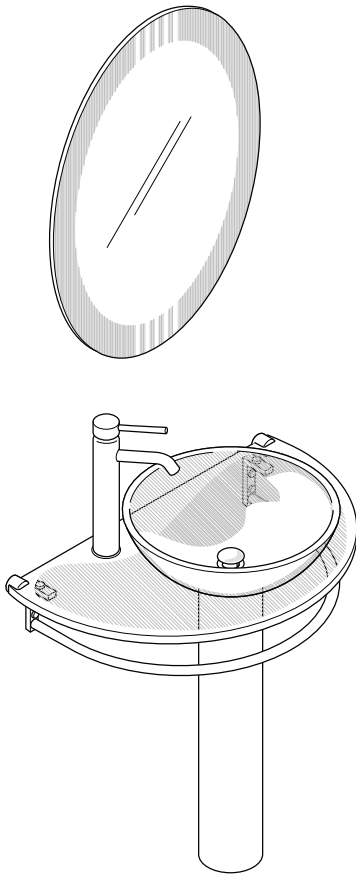

VANITY
 front view

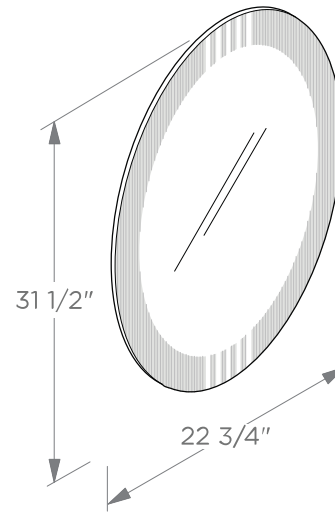
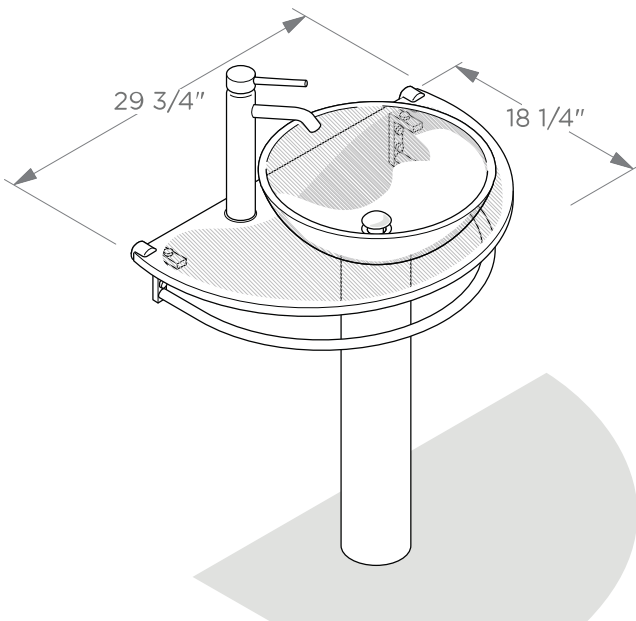

MIRROR
 front view

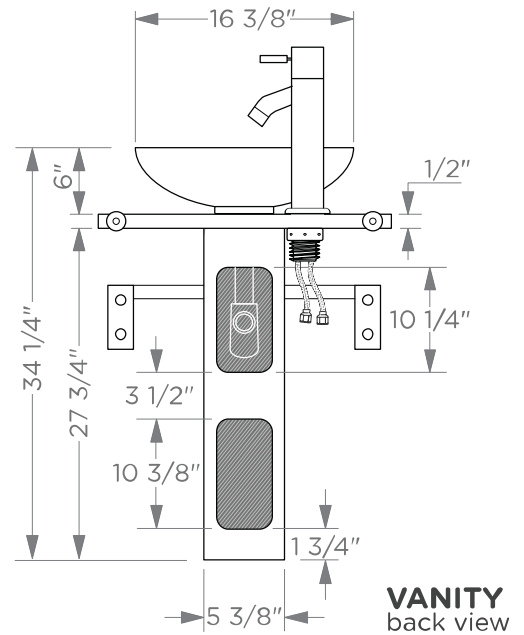

VANITY
 back view

! ALL DIMENSIONS & SPECIFICATIONS ARE APPROXIMATE AND SUBJECT TO CHANGE WITHOUT NOTICE.

TOOLS FOR ASSEMBLY

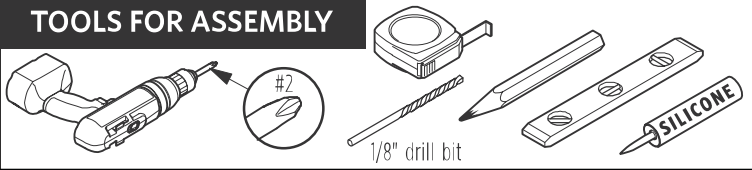

PARTS

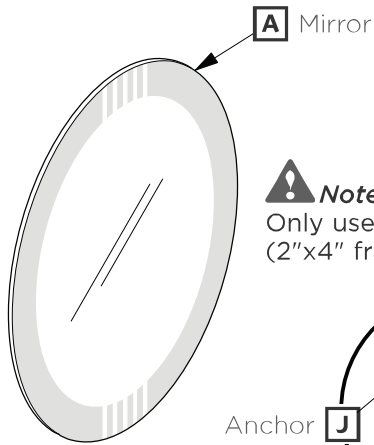
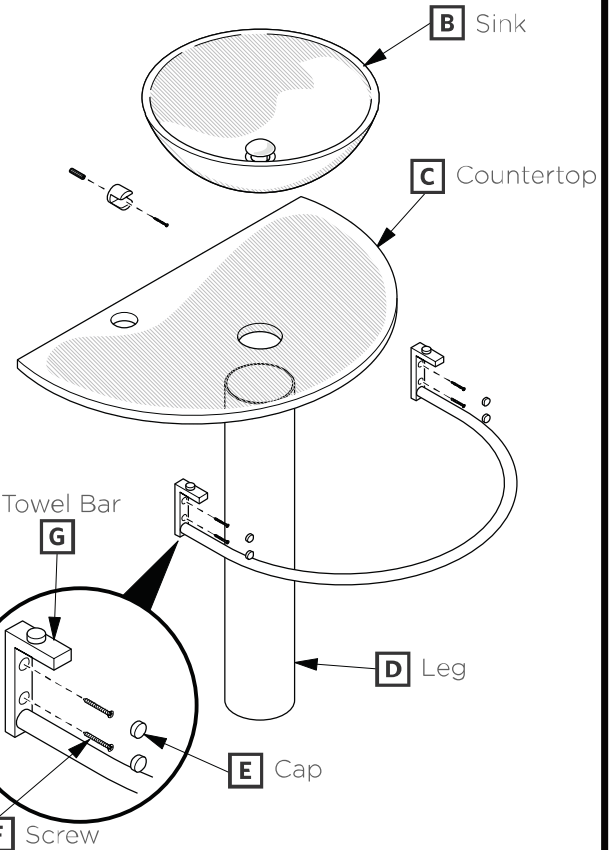

Note:
Only use anchors (J) if stud (2"x4" frame) is not available.

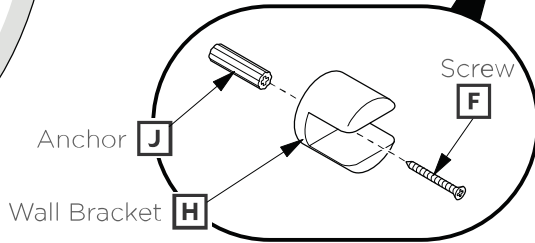

1. Install wall brackets (H).

CONSULT AN EXPERT FOR THE PROPER SCREWS/BOLTS TO USE WHEN ATTACHING TO VARIOUS WALL CONSTRUCTIONS. SCREWS PROVIDED DO NOT ATTACH TO ALL WALL CONSTRUCTION TYPES.



2. Locate a leg (D) & install countertop (C).

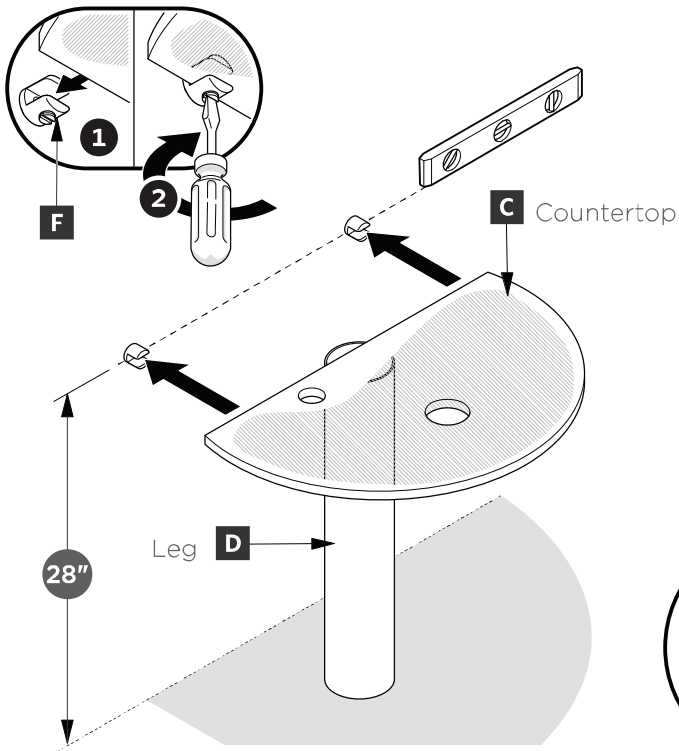

3. Install sink (B) & towel bar (G).

4. Install mirror (A).

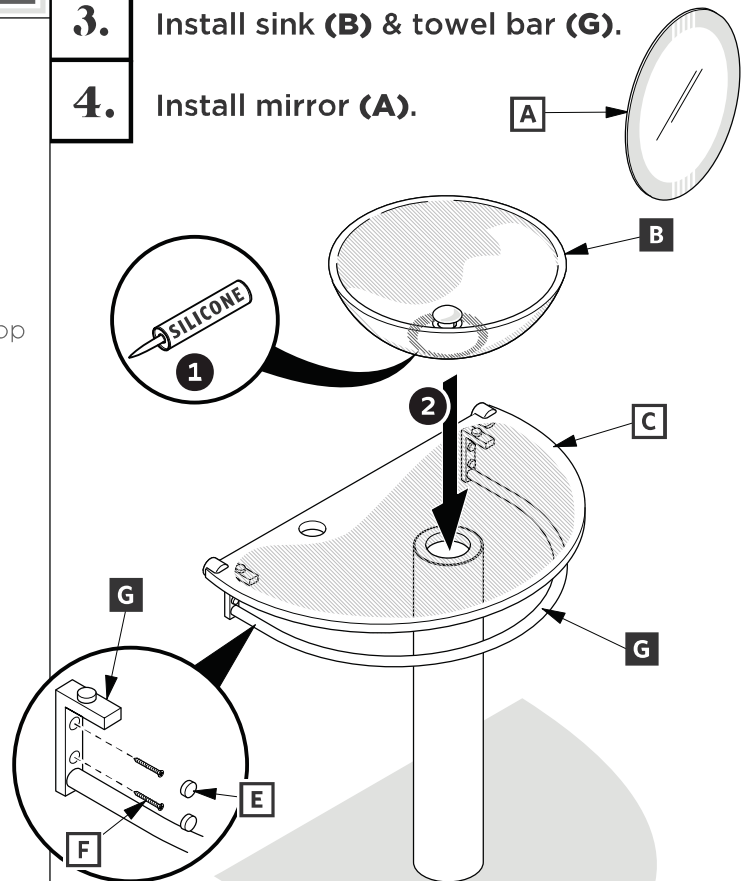

P-TRAP & POP-UP

INSTALLATION INSTRUCTIONS

Your item may appear slightly different from the illustration.

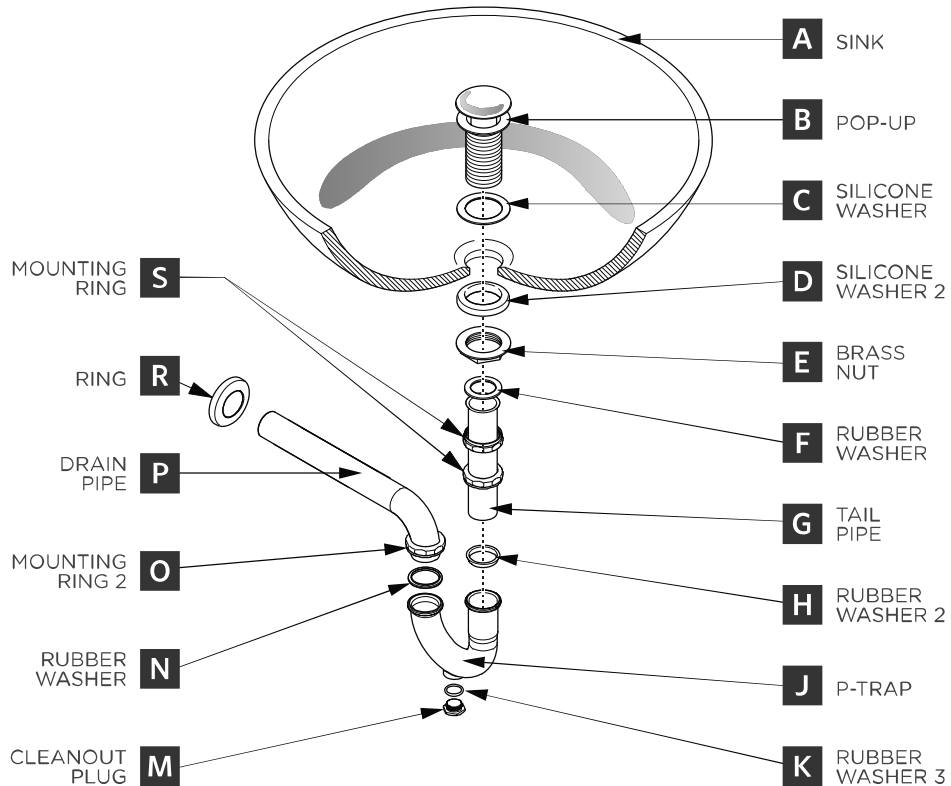

POP-UP INSTALLATION

FOR SINKS WITHOUT OVERFLOW

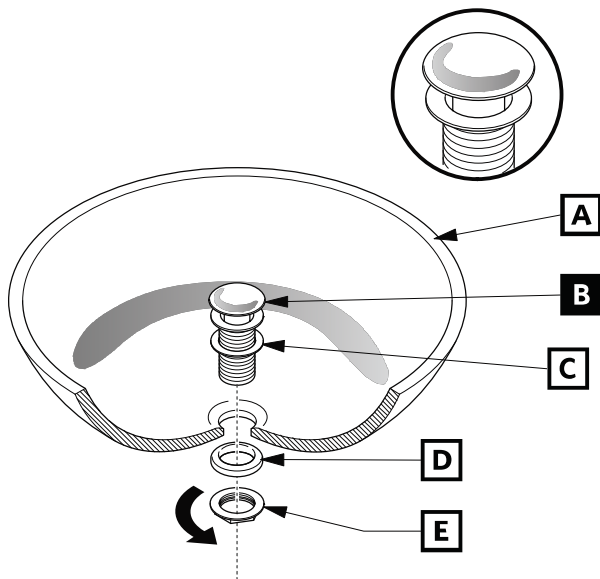

OR

FOR SINKS WITH OVERFLOW

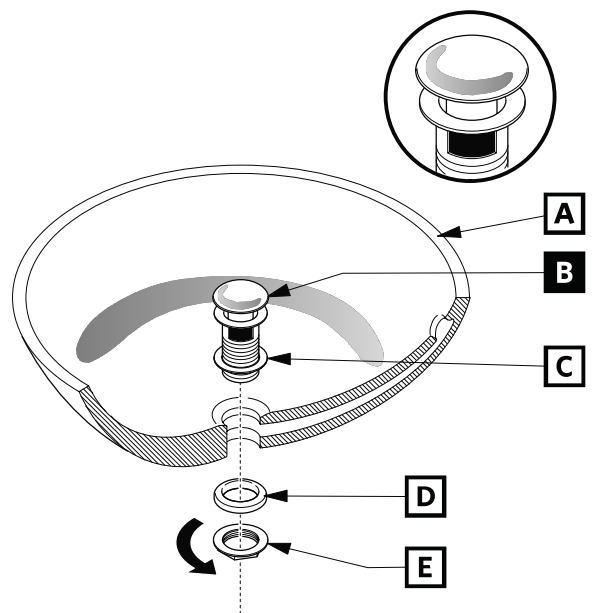

P-TRAP INSTALLATION

1. Install tail pipe (G)

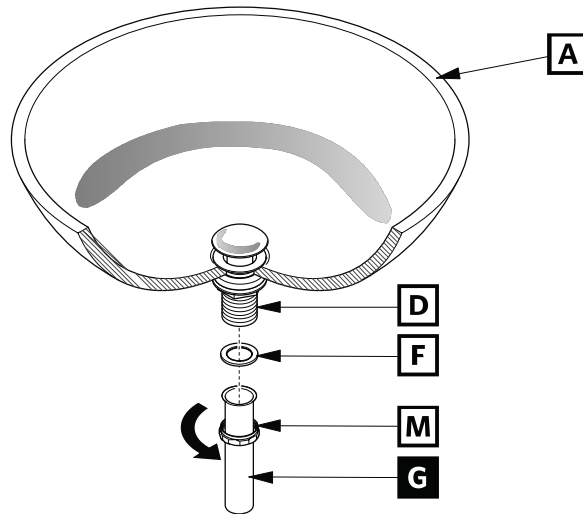

2. Install P-trap (J)

