

Specification:

1. Finish: White
2. Hardware: 370MB (2 pcs)
3. Hinge: 700.0537.25+600.1234.05 (2 pcs)
4. Slide: USE58-300-18+US-CLIP-4W (1 set)
5. Jewel Case: TOSSI4-REPL
6. Lid Stay (1 pcs)
7. Bowl: H8910WH
8. The tolerance is +/- 1/8"

	ITEM#: VN-WAV-36-WH-XX		MATERIAL:	
	FINISH:		WEIGHT:	
<p>PROPRIETARY AND CONFIDENTIAL</p> <p>THE INFORMATION CONTAINED IN THIS DRAWING IS THE SOLE PROPERTY OF HARDWARE RESOURCES INC. ANY REPRODUCTION IN PART OR AS A WHOLE WITHOUT THE WRITTEN PERMISSION OF HARDWARE RESOURCES INC. IS PROHIBITED.</p>	TOLERANCE UNLESS OTHERWISE SPECIFIED: X ±0.20 X.X ±0.10 X.XX ±0.05 ANGULAR: ±0.5°		UNITS:	DATE: Jan-17-19
	DO NOT SCALE DRAWING		SIZE:	APPROVED BY: Alexander.W
			SHEET:	RELEASE LEVEL:
			REVISION:	

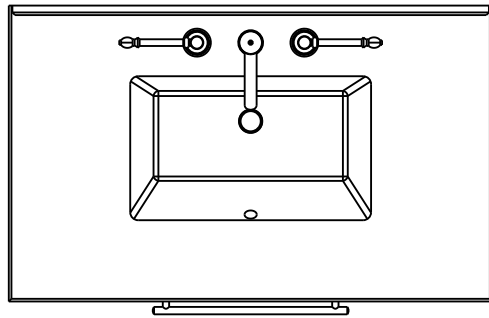
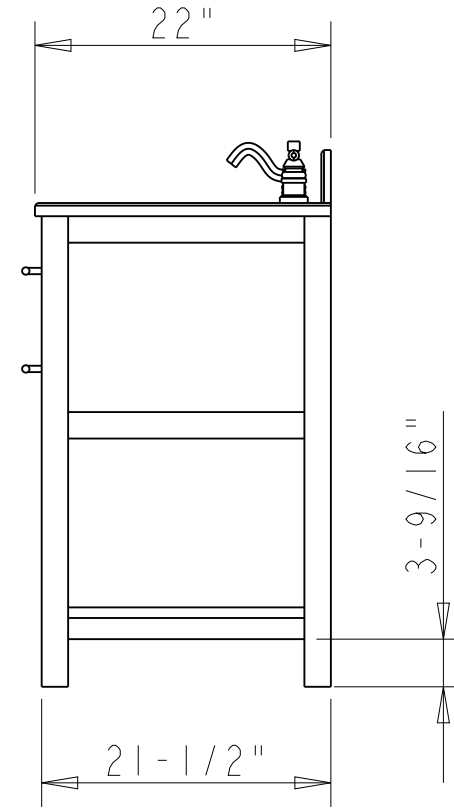
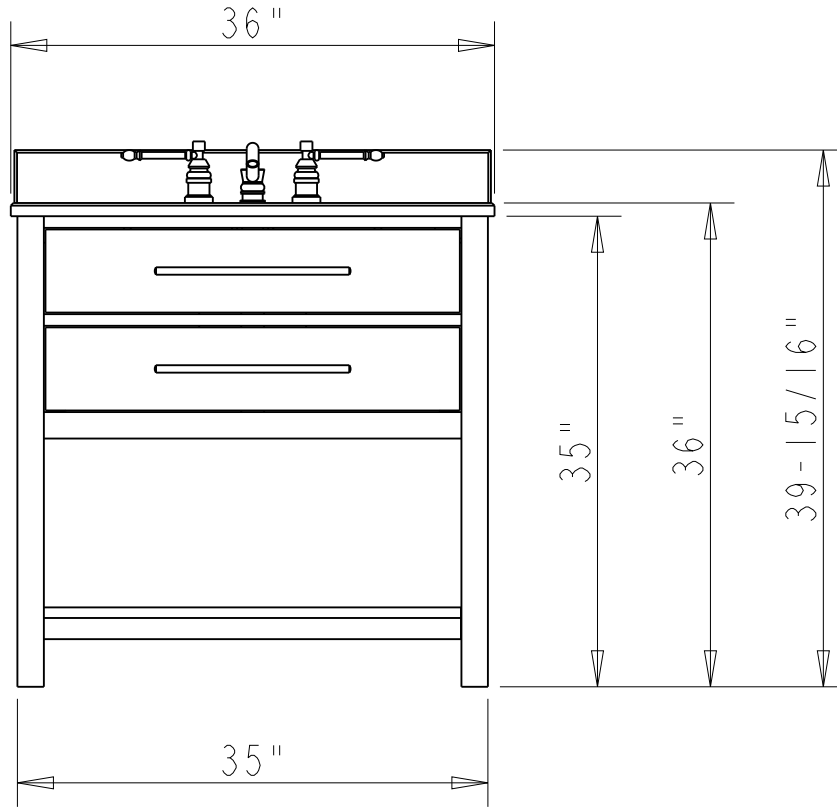

	ITEM#: VN-WAV-36-WH-XX		MATERIAL:		
	FINISH:		WEIGHT: 9		
<p>PROPRIETARY AND CONFIDENTIAL</p> <p>THE INFORMATION CONTAINED IN THIS DRAWING IS THE SOLE PROPERTY OF HARDWARE RESOURCES INC. ANY REPRODUCTION IN PART OR AS A WHOLE WITHOUT THE WRITTEN PERMISSION OF HARDWARE RESOURCES INC. IS PROHIBITED.</p> <p>DO NOT SCALE DRAWING</p>	TOLERANCE UNLESS OTHERWISE SPECIFIED:		PROJECTION		
	UNITS: X ±0.20 X.X ±0.10 X.XX ±0.05 ANGULAR: ±0.5°	DRAWN BY: Alexander.W	DATE: Jan-17-19		
	SIZE: SHEET:	APPROVED BY:	DATE:		
	RELEASE LEVEL:	REVISION:			

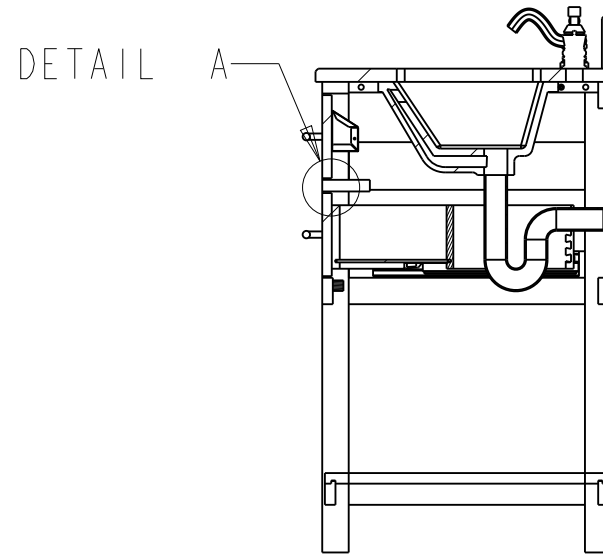
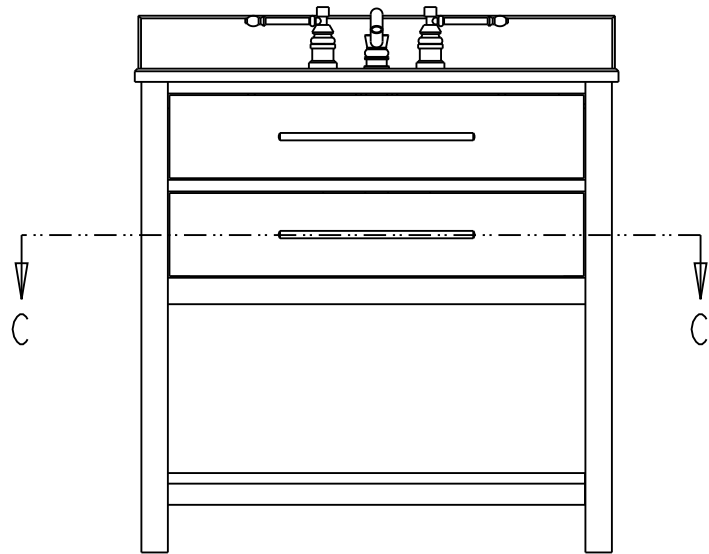

SECTION A-A

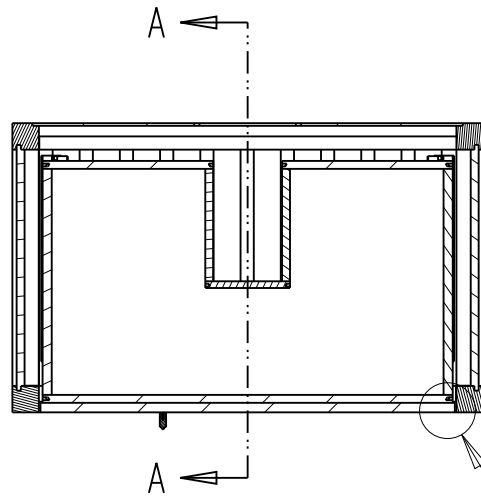

SECTION C-C

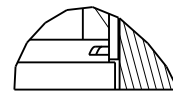

1/8"
DETAIL B
SCALE 0.200

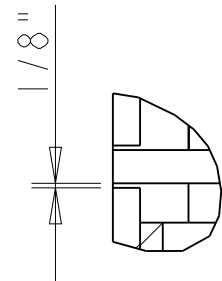

1/8"
DETAIL A
SCALE 0.200

	ITEM#: VN-WAV-36-WH-XX	MATERIAL:
	FINISH:	WEIGHT: 9
PROPRIETARY AND CONFIDENTIAL THE INFORMATION CONTAINED IN THIS DRAWING IS THE SOLE PROPERTY OF HARDWARE RESOURCES INC. ANY REPRODUCTION IN PART OR AS A WHOLE WITHOUT THE WRITTEN PERMISSION OF HARDWARE RESOURCES INC. IS PROHIBITED.	TOLERANCE UNLESS OTHERWISE SPECIFIED: X ±0.20 X.X ±0.10 X.XX ±0.05 ANGULAR: ±0.5°	PROJECTION:
DO NOT SCALE DRAWING	UNITS: DRAWN BY: Alexander.W APPROVED BY: SHEET: RELEASE LEVEL:	DATE: Jan-17-19 DATE: REVISION: