

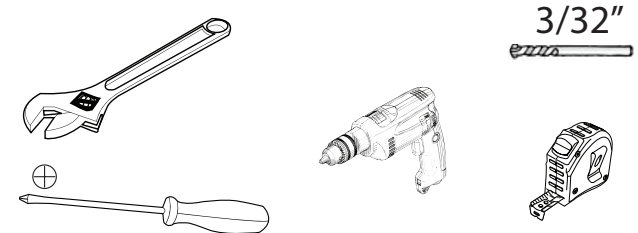

# T-5190-0114 Series Cloth Hamper Installation Template

<p><b>TOOLS REQUIRED:</b></p>  <p>3/32"</p>	<p><b>ESTIMATED ASSEMBLY TIME:</b></p> <p><b>20 MIN</b></p>	<p><b>CARE AND MAINTENANCE:</b></p> <p><b>CLEAN WITH A DAMP CLOTH AND WIPE PARTS DRY</b></p>	<p><b>PARTS LIST:</b></p> <p><b>PULLOUT CHASSIS</b>  <b>HAMPER CONTAINER CHASSIS</b>  <b>HAMPER CONTAINER(S)</b>  <b>(8) #6 X 1/2" FLAT HEAD SCREWS</b>  <b>(5) #8 X 3/4" PAN HEAD SCREW</b>  <b>DOUBLE SIDED TAPE</b></p>
--	---	--	--

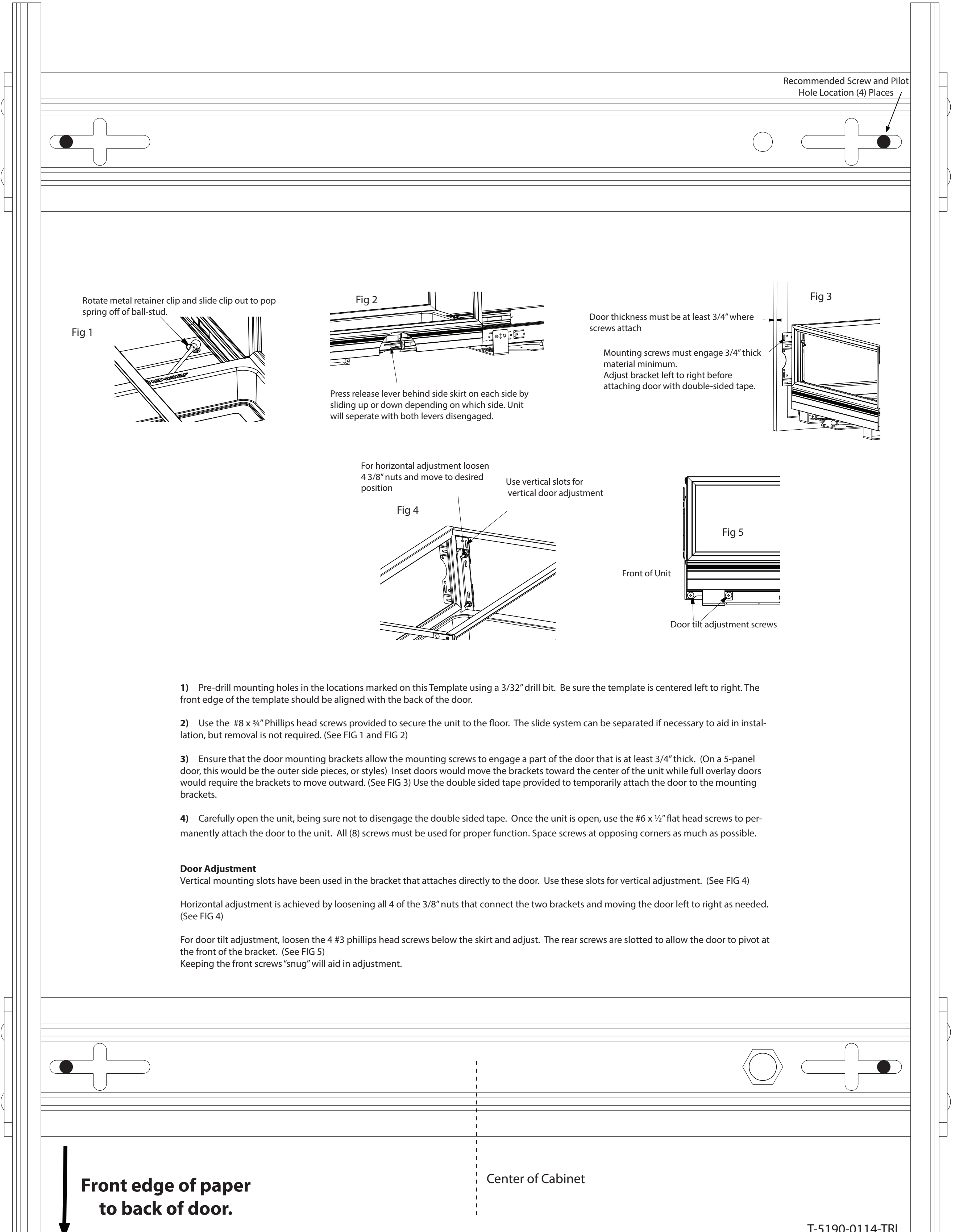

- 1) Pre-drill mounting holes in the locations marked on this Template using a 3/32" drill bit. Be sure the template is centered left to right. The front edge of the template should be aligned with the back of the door.
  - 2) Use the #8 x 3/4" Phillips head screws provided to secure the unit to the floor. The slide system can be separated if necessary to aid in installation, but removal is not required. (See FIG 1 and FIG 2)
  - 3) Ensure that the door mounting brackets allow the mounting screws to engage a part of the door that is at least 3/4" thick. (On a 5-panel door, this would be the outer side pieces, or styles) Inset doors would move the brackets toward the center of the unit while full overlay doors would require the brackets to move outward. (See FIG 3) Use the double sided tape provided to temporarily attach the door to the mounting brackets.
  - 4) Carefully open the unit, being sure not to disengage the double sided tape. Once the unit is open, use the #6 x 1/2" flat head screws to permanently attach the door to the unit. All (8) screws must be used for proper function. Space screws at opposing corners as much as possible.
- Door Adjustment**  
 Vertical mounting slots have been used in the bracket that attaches directly to the door. Use these slots for vertical adjustment. (See FIG 4)
- Horizontal adjustment is achieved by loosening all 4 of the 3/8" nuts that connect the two brackets and moving the door left to right as needed. (See FIG 4)
- For door tilt adjustment, loosen the 4 #3 phillips head screws below the skirt and adjust. The rear screws are slotted to allow the door to pivot at the front of the bracket. (See FIG 5)  
 Keeping the front screws "snug" will aid in adjustment.