

- NOTES:  
 1. PRODUCT DESIGNED FOR 3/4" WALL FRAMELESS CABINET.  
 2. UPPER TRAY EQUIPED WITH 250MM BALL BEARING FULL EXTENSION SLIDES.

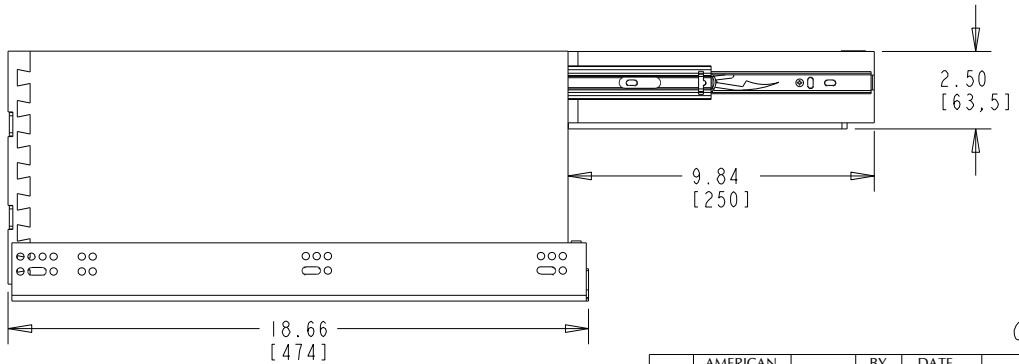
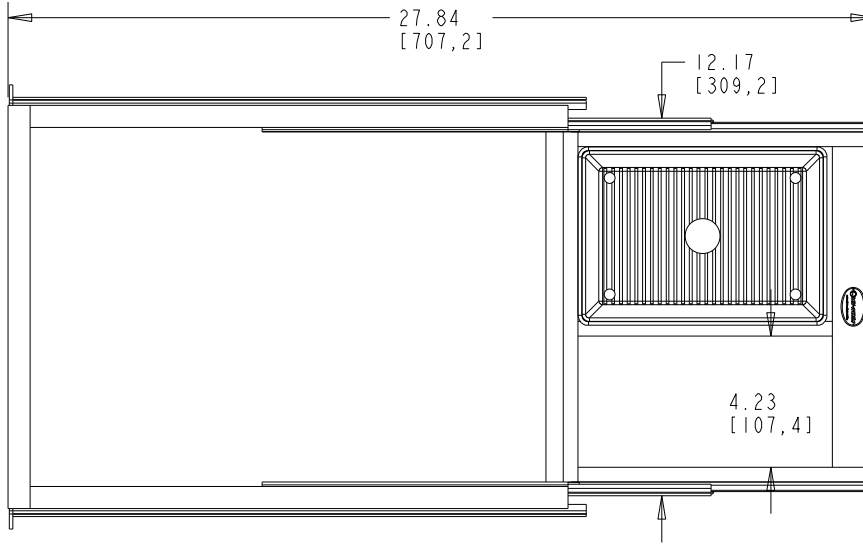
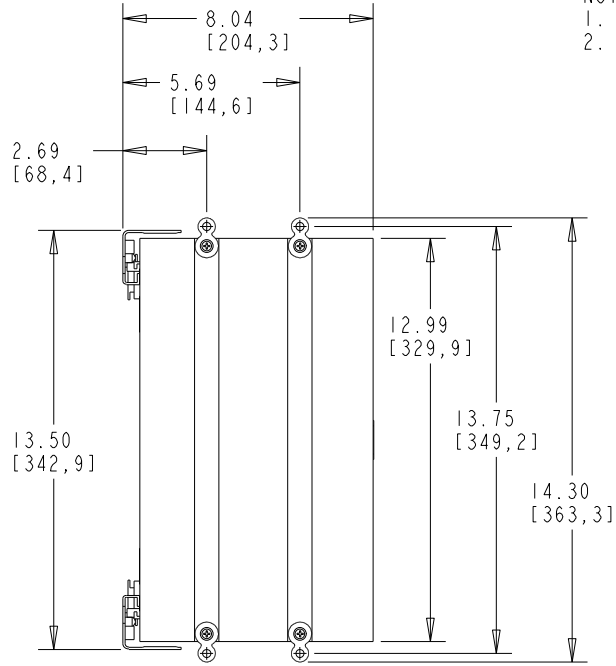

This drawing is the property of Rev-A-Shelf (RAS) and is disclosed in confidence to the extent its subject matter is original to RAS. Any vendor receiving this drawing from RAS shall hold and use this drawing for the sole benefit of RAS and shall not disclose it to, or use or reproduce it for any third party, or perform any act adverse to the interest of RAS with respect to this drawing without the express written permission of RAS. Vendors shall not revise any physical, dimensional or performance characteristic unless authorized by Rev-A-Shelf Engineering.

REV.	DATE	BY	DESCRIPTION OF CHANGE

INCH [MM]	AMERICAN PROJECTION	DRAWN	BY	DATE	REV-A-SHELF, INC.
		KRR		9-13-17	
TOLERANCES MAT. DEC. (WOOD) .XX ±.03 [.8mm] (OTHER) .XX ±.02 [1.5mm] (ALL) .XXX ±.005 [1.3 mm] FRACTIONS ±1/32 [1.8 mm]					SIZE B
ANGLES ±1/2°			MATERIAL		DRAWING NO. 4VDOHT-343FLSC-1
FINISH			PART NO. 4VDOHT-343FLSC-1		SCALE 0.250 SHEET OF 1 2

CUSTOMER DRAWING

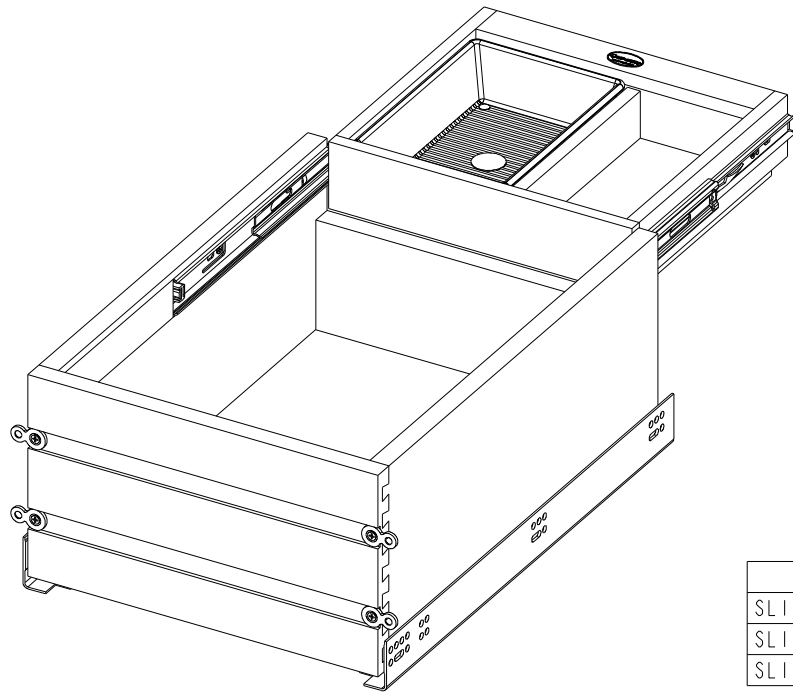

PART DIMENSIONS		
	MIN	MAX
WIDTH	13.50	
DEPTH	18.66	27.84
HEIGHT	8.04	
WEIGHT		
DIAMETER		
RADIUS		
CONTAINER CAPACITY		
CONTAINER UOM		

MIN CABINET OPENING				
	FACE FRAME	FRAMELESS	INSET FACE FRAME	INSET FRAMELESS
WIDTH	13.50	13.50	13.50	13.50
DEPTH	18.75	18.75	19.50	19.50
HEIGHT	8.25	8.25	8.25	8.25

TOP DRAWER SLIDE SPECIFICATIONS				
SLIDE TYPE	BALL BEARING	SLIDE EXTENSION	FULL	MAX WEIGHT RATING
SLIDE CLOSING	NORMAL	SLIDE LENGTH	9.84 [250 MM]	
SLIDE MOUNTING	SIDE	SLIDE FINISH	ZINC	75LB

BOTTOM SLIDE SPECIFICATIONS				
SLIDE TYPE	BLUM BLUMOTION	SLIDE EXTENSION	FULL	MAX WEIGHT RATING
SLIDE CLOSING	SOFT	SLIDE LENGTH	18.00 [457 MM]	
SLIDE MOUNTING	SIDE	SLIDE FINISH	ZINC	100LB

CUSTOMER DRAWING

This drawing is the property of Rev-A-Shelf (RAS) and is disclosed in confidence to the extent its subject matter is original to RAS. Any vendor receiving this drawing from RAS shall hold and use this drawing for the sole benefit of RAS and shall not disclose it to, or use or reproduce it for any third party, or perform any act adverse to the interest of RAS with respect to this drawing without the express written permission of RAS. Vendors shall not revise any physical, dimensional or performance characteristic unless authorized by Rev-A-Shelf Engineering.

REV.	DATE	BY	DESCRIPTION OF CHANGE

INCH [MM]	AMERICAN PROJECTION	DRAWN	BY	DATE	SCALE
			KRR	9-13-17	
					SHEET OF 2 2
		MATERIAL	DRAWING NO.	SCALE	
FINISH		PART NO.	4VDOHT-343FLSC-1	0.250	

REV-A-SHELF, INC.

FRAMELESS 15" VANITY TIERED DRAWER

4VDOHT-343FLSC-1

4VDOHT-343FLSC-1