

No. 8200 Drawer Slide Installation Instructions

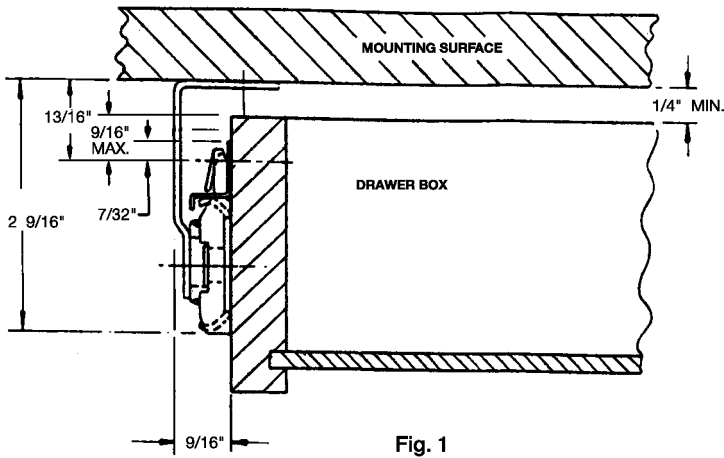

Fig. 1

Step 1.

Determine right hand case member from left hand case member by locating the front molded lock (See Fig. #2). With the front molded lock pointing towards you, identify whether the slide is left hand or right hand by making sure the brackets turn inward.

Step 2.

Mount case members to the mounting surface using Fig. #1 for key dimensions. Mounting brackets are slotted for installation adjustment. Note Fig. #3. The front bracket mounting hole is centered $2 \frac{1}{32}$ " from the front edge of the slide. Therefore, if a flush drawer front is desired, center the front mounting bracket $2 \frac{1}{32}$ " + drawer front thickness, from the front edge of the mounting surface.



Top

Fig. #2

Bottom

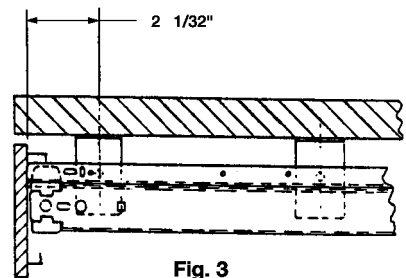

Fig. 3

300285-6 IS135 9/98

Step 3.

Fasten drawer channels (non-handed) flush with the back of the drawer front as show in Fig. #4. Screw holes for drawer members *must not* be drilled any lower than $\frac{9}{16}$ " from the top edge of the drawer side. This will provide a minimum required clearance of $\frac{1}{4}$ " between the drawer sides and mounting surface for drawer insertion. (See Fig. #5)

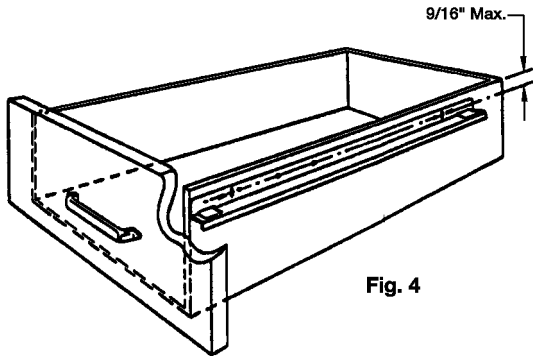

Fig. 4

Step 4.

Pull case members all the way out. Insert drawer by fitting drawer members under the case member hooks and snapping down over the front lock. (See Fig. #5)

Step 5.

To release the drawer, push the front lock in towards the drawer, lift and remove.

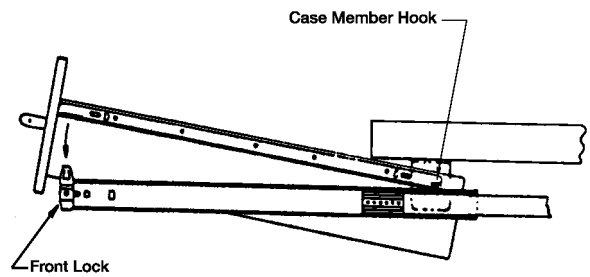

Fig. 5

300285-6 IS135 9/98