



8407 Full Extension Roll-Out Drawer Slide

SPECIFICATIONS

- 1/2" minimum side clearance per side required.
- Triple precision steel ball bearing movement.
- Metal ball bearing retainer for durability and quiet operation.
- Lever disconnect for easy drawer removal and Insertion.
- Electro-plated bright zinc chromate with clear lacquered topcoat for better corrosion resistance and appearance. Black zinc chromate finish available.
- Full 32mm pattern with direct access openings for quicker mounting without extending the slide.

KV 8407 Major Dimensions and Mounting Hole Locations

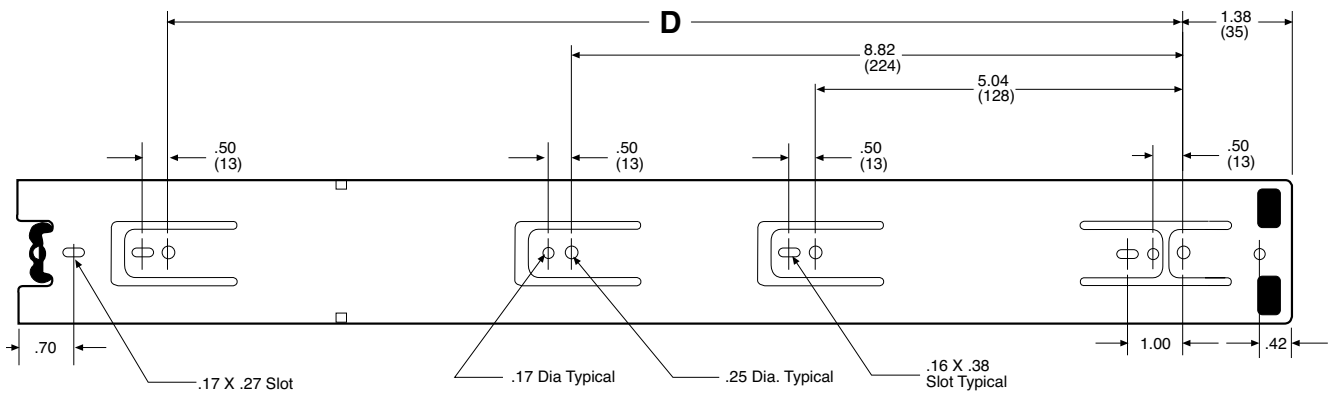
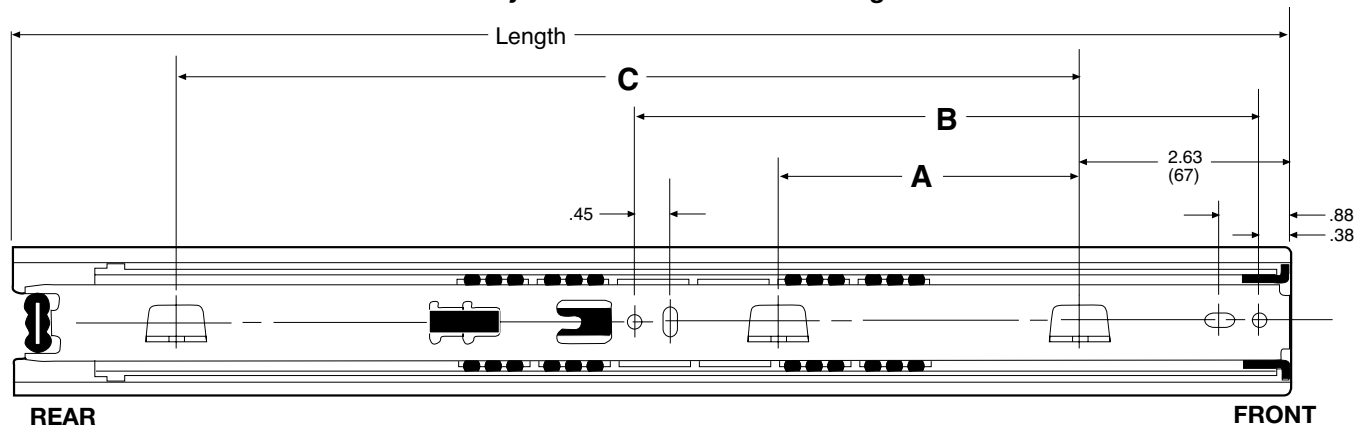

CROSS SECTION

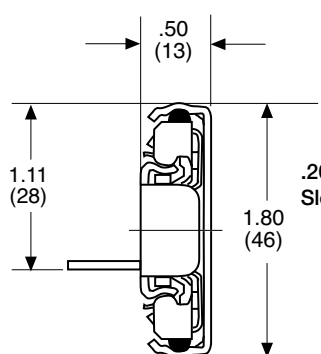

TOP VIEW

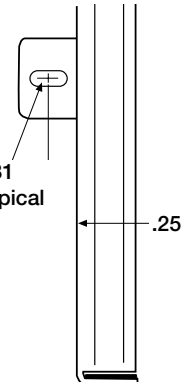

Dimensions in () are in millimeters.

Size	Length	Travel	A	B	C	D
16"	16.00	16.00	3.78 (96)	7.82 (199)	11.34 (288)	12.60 (320)
18"	18.00	18.00	3.78 (96)	8.82 (224)	11.34 (288)	13.86 (352)
20"	20.00	20.00	6.30 (160)	9.82 (249)	15.12 (384)	16.38 (416)
22"	22.00	22.00	7.56 (192)	10.82 (275)	15.12 (384)	18.90 (480)
24"	24.00	24.00	7.56 (192)	11.82 (300)	15.12 (384)	18.90 (480)

PATENT PENDING

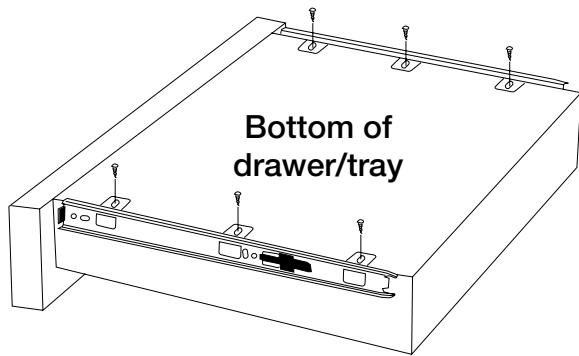

Figure E

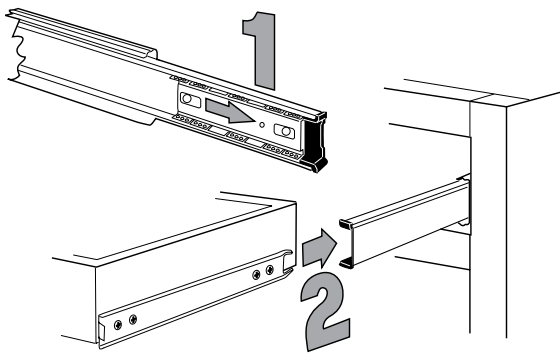

Figure F

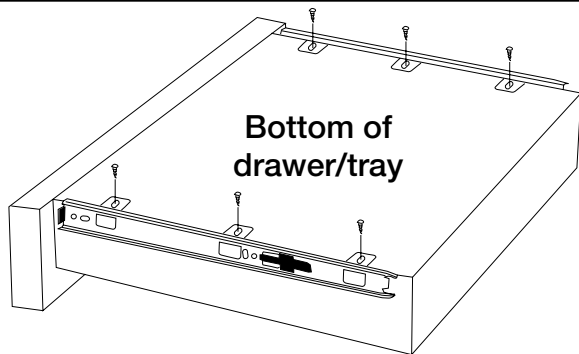

Figure G

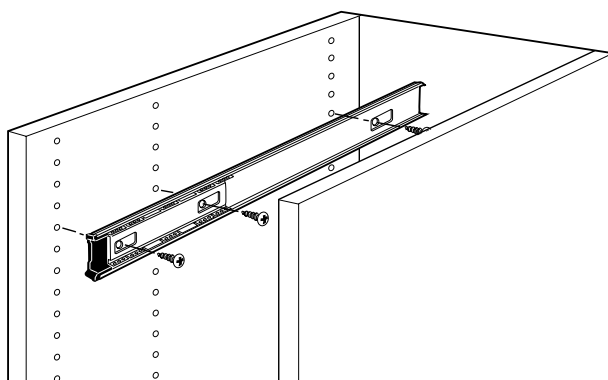

Figure H

Step 3. Part Preparation and Identification.

Separate the slide members by depressing the disconnect lever. See **Figure C**. The drawer members are stamped “DR” (Drawer Right) and “DL” (Drawer Left) for easier identification. The cabinet members are non-handed.

Step 4. Install Cabinet Members.

Install cabinet members as shown in **Figure D**. Check the location of cabinet members on both sides and adjust as needed. Cabinet member should be flush with front of face frame. Secure slide to rear socket with a screw.

Step 5. Install Drawer Members.

Install the drawer member as shown in **Figure G**. Fasten from bottom through holes in the shelf tabs.

Step 6. Insert Drawer.

Check that ball retainer is latched in the forward position. Insert drawer members and close completely, as shown in **Figure F**.

Step 7. Adjust and Secure.

Open and close drawer while checking for proper fit. Adjust as needed. Secure the drawer member with two screws in the round holes.

Frameless Application

Step 1. Part Preparation and Identification.

Separate the slide members by depressing the disconnect lever, as shown in **Figure C**.

Step 2. Install Drawer Members.

Install the drawer member as shown in **Figure G**. Fasten from bottom through holes in the shelf tabs.

Step 3. Install Cabinet Members.

Install cabinet member as shown in **Figure H**. Check the location of cabinet members on both sides. Adjustment should not be needed when mounted using the 32mm system hole pattern.

Step 4. Insert Drawer

Check that ball retainer is latched in the forward position. Insert drawer members and close completely as shown in **Figure F**.

Step 5. Adjust and Secure.

Open and close drawer while checking for proper fit. Adjust as needed. Secure the drawer member with two screws in the round holes.

KV 8402 Rear Bracket Dimensions

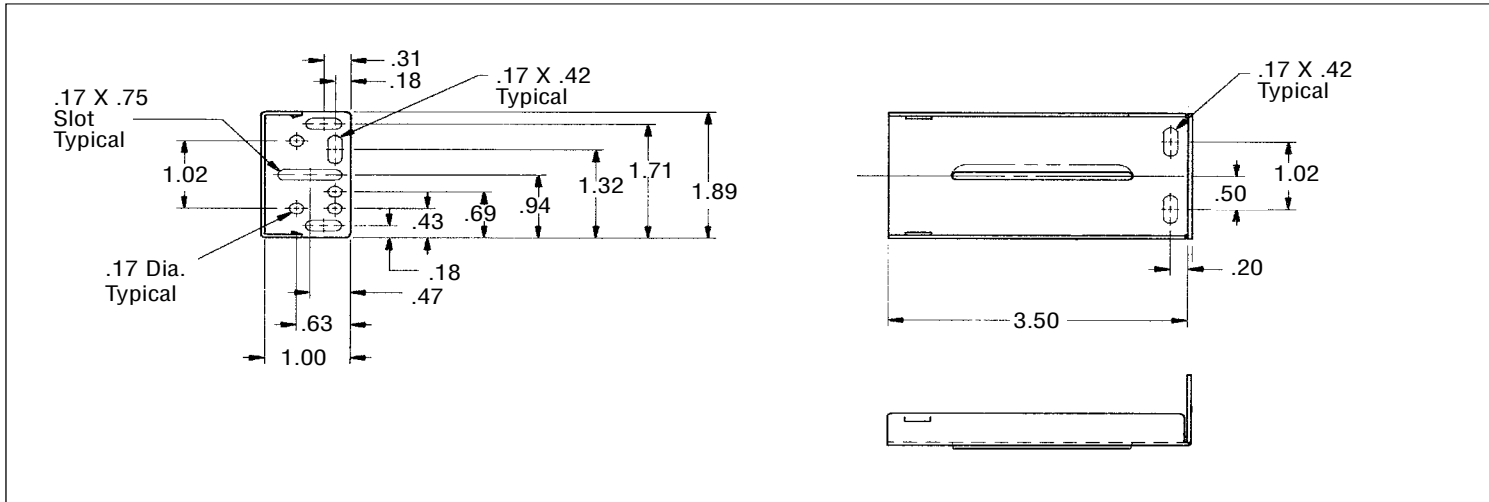

Limited Lifetime Warranty

Knape & Vogt Manufacturing Company guarantees its drawer slides and builder's hardware products against failure or defects for so long as the purchaser or end user owns them. This warranty is void if any damage to the product is due to misuse, abuse, neglect, accident, improper installation or any uses contrary to the instructions accompanying the product. This warranty covers the cost of the defective part and not the cost of removal, installation or other incidental charges. The foregoing are the purchaser's exclusive remedies. Knape & Vogt Manufacturing Company assumes no liability for special or consequential damages.

Replacement product may be obtained by returning the product, transportation charges prepaid, together with a receipt of purchase or other documents acknowledging the sale of the product, addressed to the Knape & Vogt Manufacturing Company, Attention: Customer Service Department.

The warranty set forth above is in lieu of any other warranties, express or implied, including warranties of merchantability and fitness for use.



KNAPE & VOGT®