

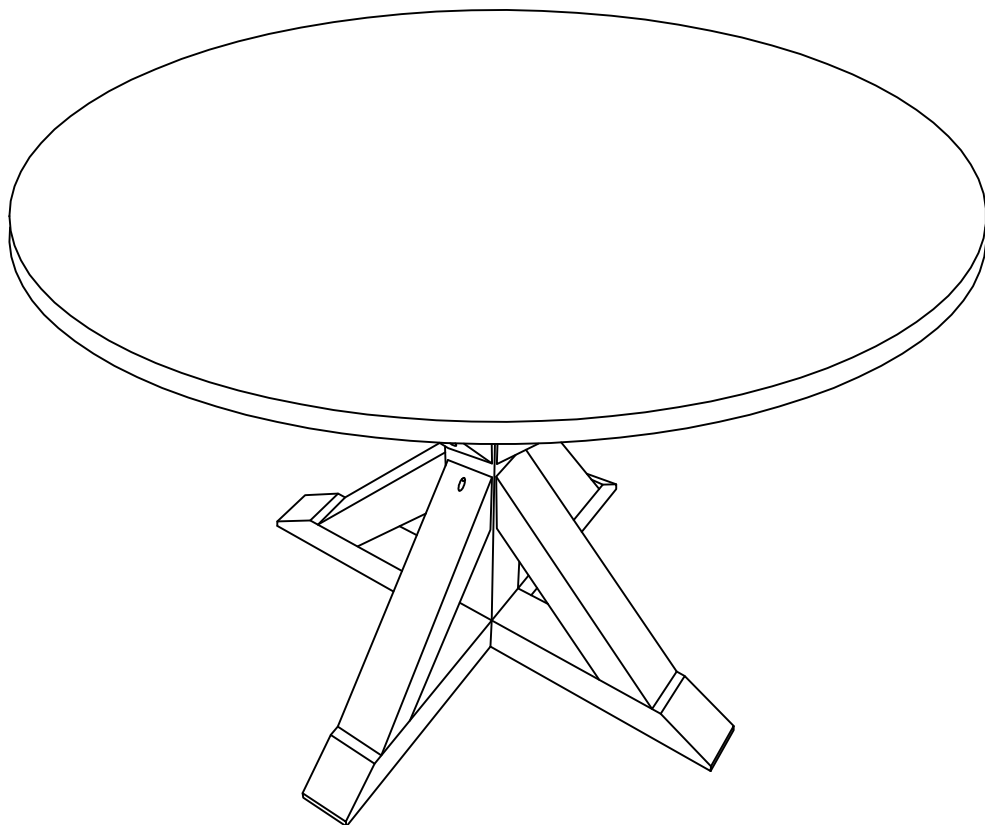

Round Dining Table



CF2011



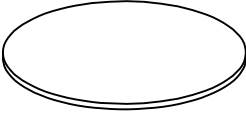
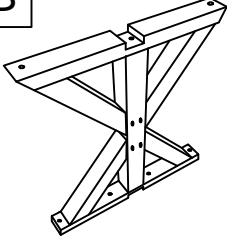
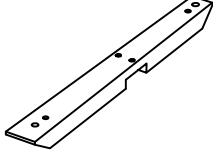
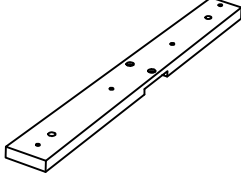
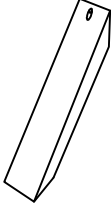

PART LIST

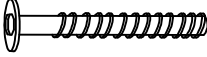
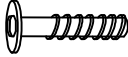
<p>A</p> 	<p>B</p> 	<p>C</p> 	<p>D</p> 	<p>E</p> 
<p>Table Top 1 PC</p>	<p>Leg 1 PC</p>	<p>Bottom Rail 1 PC</p>	<p>Top Rail 1 PC</p>	<p>Support Rail 4 PCS</p>

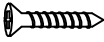
HARDWARE LIST

<p>#1</p>  <p>M6 x 80mm</p>	<p>#2</p>  <p>M6 x 35mm</p>	<p>#3</p> 	<p>#4</p> 	<p>#5</p>  <p>M4 x 38mm</p>
<p>Long Bolt 2 PCS (Extra 1)</p>	<p>Bolt 12 PCS (Extra 1)</p>	<p>Spring Washer 14 PCS (Extra 1)</p>	<p>Flat Washer 14 PCS (Extra 1)</p>	<p>Screw 6 PCS (Extra 1)</p>

<p>#6</p>  <p>M4</p>	<p>#7</p> 
<p>Allen Wrench 1 PC</p>	<p>Wooden Cover 4 PCS</p>

ADDITIONAL TOOLS (Not Provided)

Note: It is not recommended to use power tools during assembly.

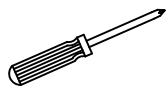

Phillips Head Screwdriver



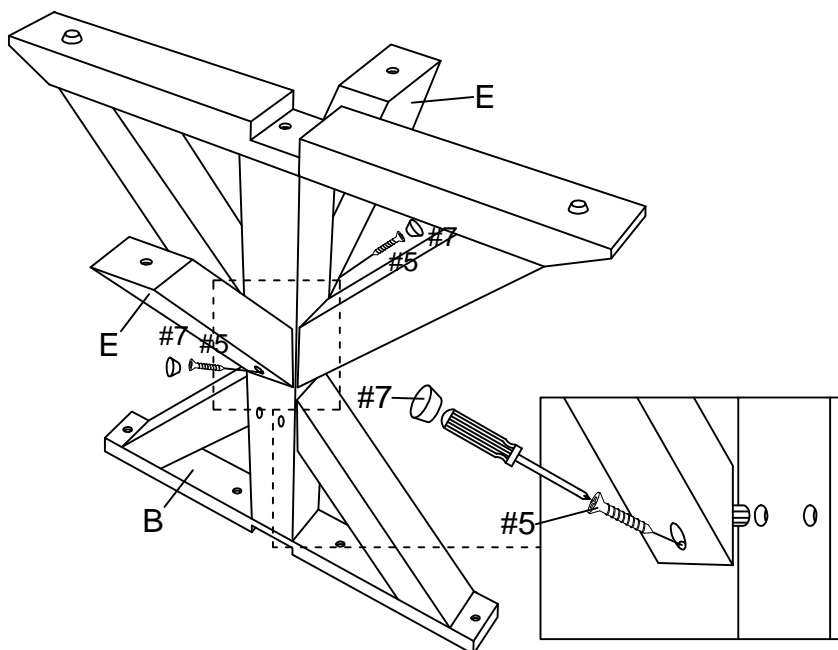

Step 1 . Attach support rails (part E) to leg (part B) using screws (part #5) and phillips head screwdriver. Attach wooden covers (part #7) to screws (part #5).

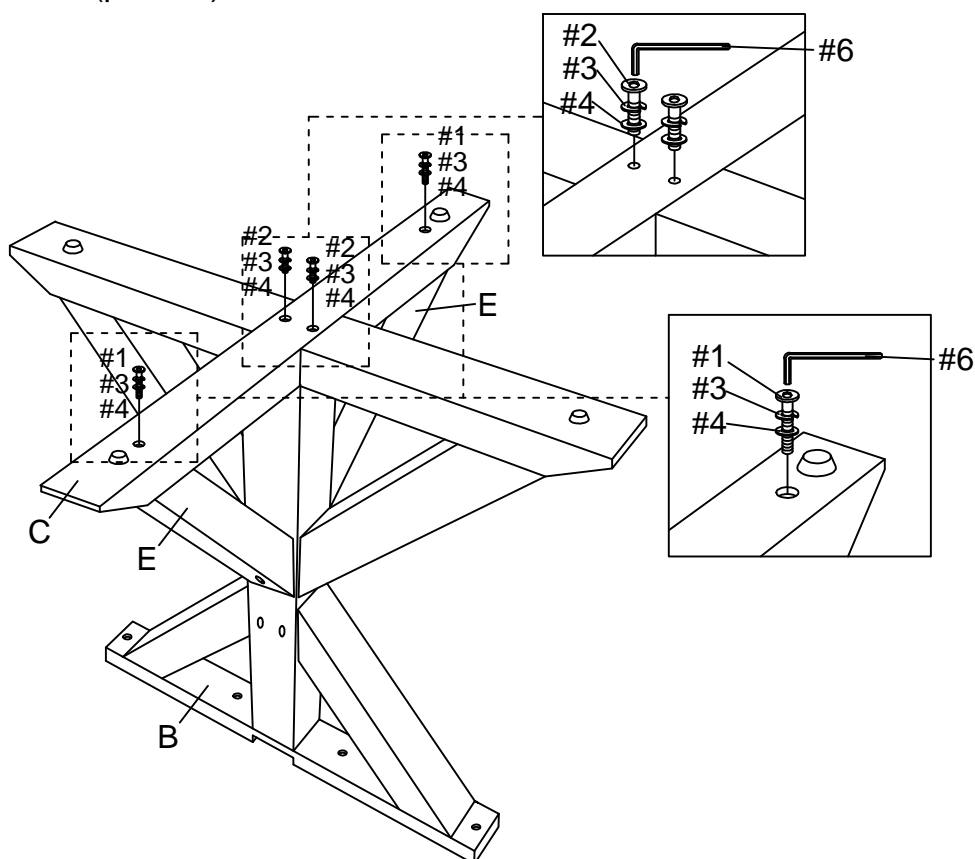

#5  x2
 #7  x2

Step 2 . Attach bottom rail (part C) to leg (part B) and support rails (part E) using long bolts (part #1), bolts (part #2), spring washers (part #3), flat washers (part #4) and allen wrench (part #6).



#1  x2
 #2  x2
 #3  x4
 #4  x4
 #6  x1



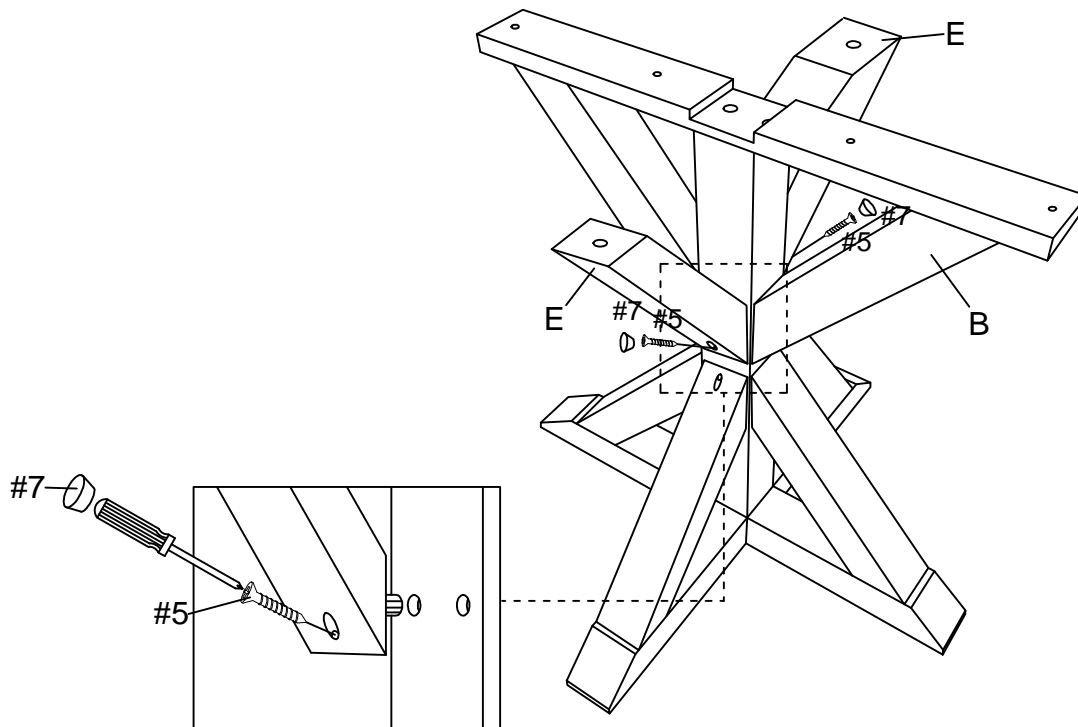

Step 3 . Carefully turn unit upright. Attach support rails (part E) to leg (part B) using screws (part #5) and phillips head screwdriver. Attach wooden covers (part #7) to screws (part #5).

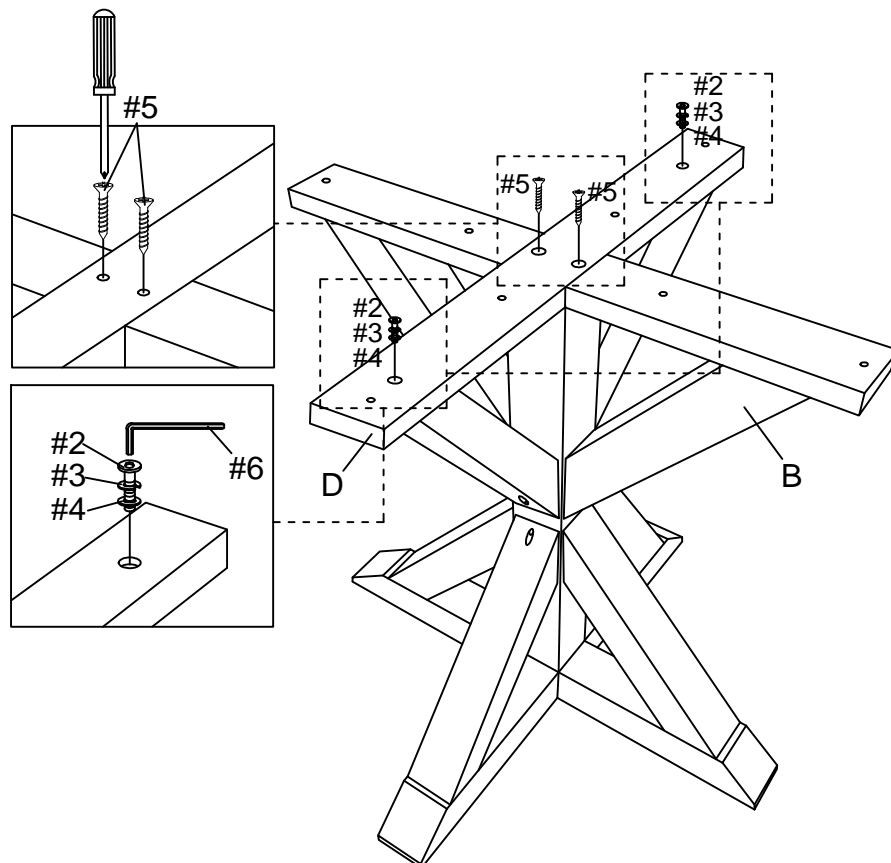

#5  x2
 #7  x2





Step 4 . Attach top rail (part D) to leg (part B) using screws (part #5), bolts (part #2), spring washers (part #3), flat washers (part #4), allen wrench (part #6) and phillips head screwdriver.

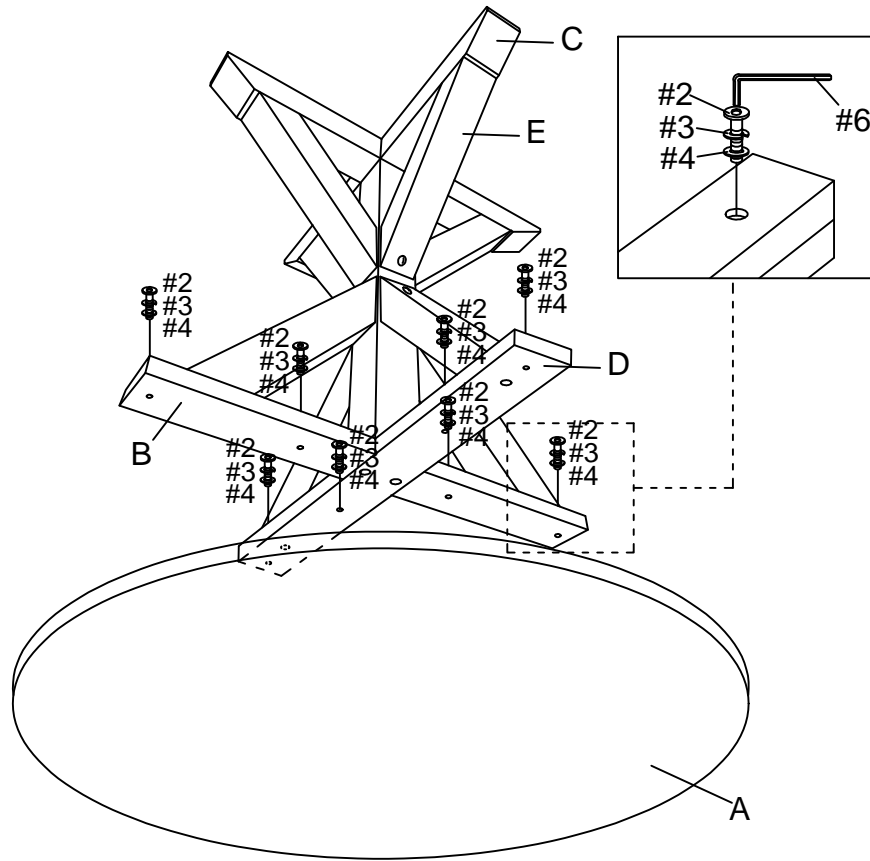

#2  x2
 #3  x2
 #4  x2
 #5  x2

Step 5 . Lay table top (part A) upside down on a soft flat surface, such as carpet. Attach assembled unit (parts B, C, D & E) to table top (part A) using short bolts (part #2), spring washers (part #3), flat washers (part #4) and allen wrench (part #6).



- | | | |
|----|---|----|
| #2 |  | x8 |
| #3 |  | x8 |
| #4 |  | x8 |
| #6 |  | x1 |

Step 6 . Carefully turn assembled unit upright.

