

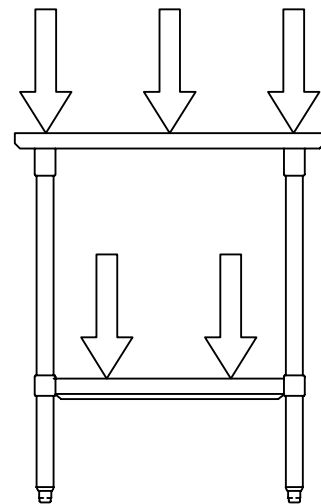

# LOAD RATINGS

ALL LOAD RATINGS ARE CALCULATED TO BE EVENLY DISTRIBUTED LOADS.

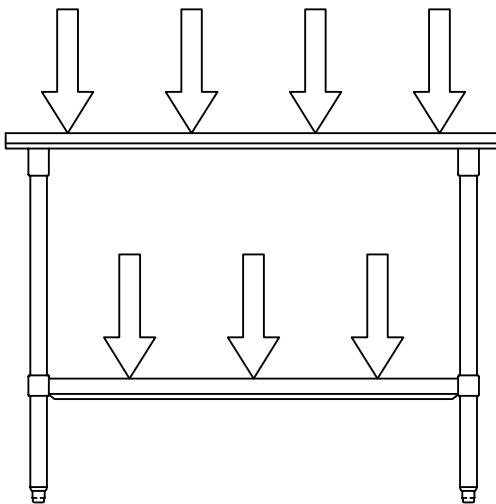
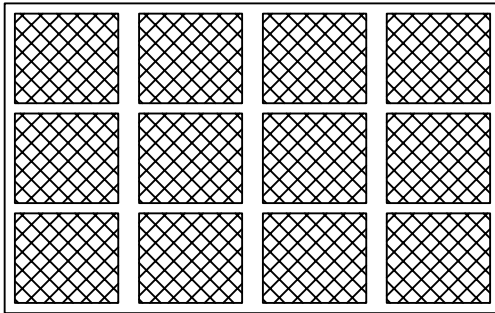

<b>EQUIPMENT STANDS - KD BASE</b>				
<b>GS6 EQUIPMENT STAND - KD BASE</b>				
WIDTH	LENGTH	WEIGHT CAPACITY (lbs.)		
		TOP	SHELF	TOTAL MAX
24, 30, 36	24	900	400	900
	36	900	400	900
	48	900	300	900
	60	860	150	900
	72-4 LEG	540	100	-
	72-6 LEG	1350	600	900
<b>MS4 MACHINE STAND - KD BASE</b>				
WIDTH	LENGTH	WEIGHT CAPACITY (lbs.)		
		TOP	SHELF	TOTAL MAX
24,30	24	900	400	900
	36	900	400	900
	48	900	300	900
<b>S16MS MACHINE STAND - KD BASE</b>				
WIDTH	LENGTH	WEIGHT CAPACITY (lbs.)		
		TOP	SHELF	TOTAL MAX
24,30	24	900	400	900
	30	900	400	900
<b>EES8 EQUIPMENT STAND - KD BASE</b>				
WIDTH	LENGTH	WEIGHT CAPACITY (lbs.)		
		TOP	SHELF	TOTAL MAX
24, 30, 36	24	720	400	720
	36	720	400	720
	48	720	300	720
	60	720	150	720
	72-4 LEG	540	100	-
	72-6 LEG	1080	400	1080

**\*ALL WEIGHT CAPACITIES ARE BASED ON EVENLY DISTRIBUTED LOADS WITH A MAX DEFLECTION OF 1/4"**

<b>EQUIPMENT STANDS - WELDED BASE</b>				
<b>GS6 EQUIPMENT STAND - WELDED BASE</b>				
WIDTH	LENGTH	WEIGHT CAPACITY (lbs.)		
		TOP	SHELF	TOTAL MAX
24, 30, 36	24	1000	1000	1000
	36	1000	750	1000
	48	1000	300	1000
	60	950	150	1000
	72-4 LEG	600	100	-
	72-6 LEG	1500	750	1500
<b>MS4 MACHINE STAND - WELDED BASE</b>				
WIDTH	LENGTH	WEIGHT CAPACITY (lbs.)		
		TOP	SHELF	TOTAL MAX
24,30	24	1000	1000	1000
	36	1000	750	1000
	48	1000	300	1000
<b>S16MS MACHINE STAND - WELDED BASE</b>				
WIDTH	LENGTH	WEIGHT CAPACITY (lbs.)		
		TOP	SHELF	TOTAL MAX
24,30	24	1000	1000	1000
	30	1000	750	1000

**\*ALL WEIGHT CAPACITIES ARE BASED ON EVENLY DISTRIBUTED LOADS WITH A MAX DEFLECTION OF 1/4"**