

SUM6

SUM6



SEM6 120V USA

A – Air Inlet Ø 150

- Motor: 900 cfm EBM
- Absorption: 400W
- Pressure: 950 Pa
- Noise level: 68 dBA



B – Air Inlet Ø 200

- Motor: 1100 cfm EBM
- Absorption: 420W
- Pressure: 920 Pa
- Noise level: 65 dBA

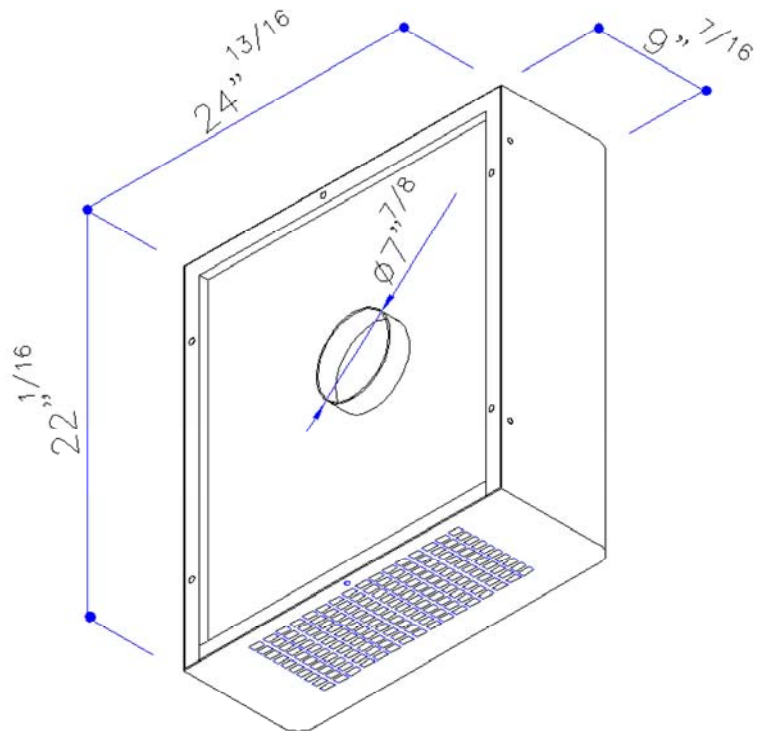

Sirius

∴kitchensource.com

☎ 1.800.667.8721