

SOFT-CLOSE UNDERMOUNT WASTE BIN

Inspect all parts and read all instructions prior to beginning assembly and installation.

1. Install Sliding Base Assembly

- Place sliding base assembly on cabinet floor in the center of the cabinet opening. Refer to chart (Fig. 1) to determine set back. Position the front edge of the front mounting strap at the designated set back.
- Once the position is determined, fasten the sliding base assembly to the cabinet floor by using 4 - #8 x 1" mounting screws through the interior holes. (Fig. 2) Tighten with a screwdriver.
- Place 2 -#8 x 1" mounting screws through the exterior holes (Fig. 3) and fasten with a Phillips head screwdriver until the head of the screw is flush with the sliding base assembly. **DO NOT OVER TIGHTEN**, as this can warp the slide.

2. Remove Door

With drill or screwdriver, remove door hinges from cabinet and door.

IMPORTANT: Door must be removed prior to waste bin chassis installation.

3. Install Waste Bin Chassis

- Lower and insert rear of chassis so that the channels on the chassis fit onto the slides on the sliding base assembly. Push chassis toward the back of the cabinet until it sits against the back of the slides and you hear a "click." (Fig. 5) The chassis is now fully seated and locked. Grasp the door mount brackets, slowly pull the chassis out of the cabinet until it stops moving. Both slides should fully extend.

NOTE: If your slides do not fully extend, your chassis is not seated properly. To correct, push the drawer slide forward until it locks into position.

Fig. 1

| SKU # | Cabinet Opening | OVERLAY CABINET Set Back | Extension Bracket Orientation | INSET CABINET | |
|-------------|-----------------|-----------------------------|-------------------------------|-------------------------|-------------------------------|
| | | | | Set Back | Extension Bracket Orientation |
| WUSC12-1-35 | 11.5-12 | 2.375 | In | 2.125" + door thickness | Not Used |
| | 14.5-15 | | Out | 2.375" + door thickness | Out |
| WUSC12-1-50 | 11.5-12 | 2.375 | In | 2.125" + door thickness | Not Used |
| | 14.5-15 | | Out | 2.375" + door thickness | Out |
| WUSC12-2-27 | 11.5-12 | 2.375 | In | 2.125" + door thickness | Not Used |
| | 14.5-15 | | Out | 2.375" + door thickness | Out |
| WUSC15-2-35 | 14.5-15 | 2.375 | In | 2.125" + door thickness | Not Used |
| | 17.5-18 | | Out | 2.375" + door thickness | Out |
| WUSC18-2-50 | 17.5-18 | 2.375 | Out | 2.375" + door thickness | Out |

Fig. 2

See Chart

Fig. 3

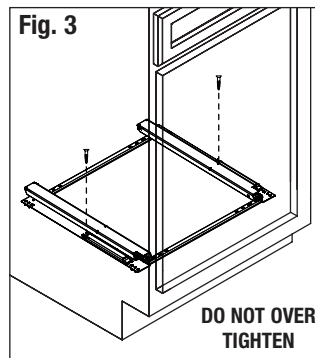
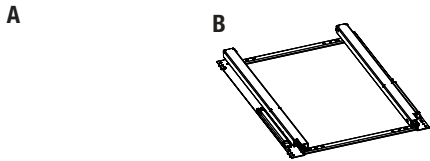

Fig. 5



Parts Included

- Waste Bin(s)
- Sliding Base Assembly (1)
- Waste Bin Chassis (1)
- Lid(s) (if supplied)
- Extension Brackets (2)
- #6 x 5/8" Mounting Screws for Door (8 = 4 + 4 extra)
- #8 x 1" Mounting Screws for Sliding Assembly (8 = 6 + 2 extra)
- #10 - 24" x 1/4" Mounting Screws (4) for Extension Brackets



Tools Required

- Phillips head screwdriver
- Drill with 1/16" (1.5mm) bit for drilling pilot holes
- Tape measure or ruler
- Pencil
- Scissors

Product Assemblies

- WUSC12-1-35PT
- WUSC12-1-35WH
- WUSC15-2-35PT
- WUSC15-2-35WH
- WUSC12-1-50PT
- WUSC12-1-50WH
- WUSC12-2-27PT
- WUSC12-2-27WH
- WUSC18-2-50PT
- WUSC18-2-50WH



KNAPE & VOGT

B. Loosen the tilt adjusting screw and adjust door mount brackets until they are parallel with the front of the cabinet according to the diagram shown. **(Fig. 6)** Once parallel, retighten screws.

4. Determine Door Bracket Position

- A. Measure the cabinet opening width. **(Fig. 7)** Refer to chart **(Fig. 1)** to determine extension bracket orientation. If brackets are not required, skip to step 5.
- B. Insert one #10 - 24 x 1/4" pan head machine screw in each round hole of the extension bracket. **(Fig. 8)** Turn 2 to 3 times.
- C. Extend sliding base assembly out of the cabinet interior to a comfortable working position. Align the pan head screws on the extension bracket with the keyholes in the door bracket. Insert through keyhole and push downward until the pan head screws are fully seated. If necessary, loosen the pan head screws slightly to verify screws are fully seated. Tighten screws. **(Fig. 8)**
- D. Ensure door brackets do not interfere with cabinet opening and set back is in desired location. If necessary, adjust sliding base assembly accordingly.

5. Install Cabinet Door to Door Bracket

- A. Ensure that the chassis in the fully closed position. Peel protective cover from tape on the brackets. Line up the cabinet door in desired position ensuring that it is level with any cabinet doors on either side. Also ensure that the spacing between the door and any drawer above is even with the spacing on your other cabinets. **(Fig. 9)**

Fig. 6



Fig. 7

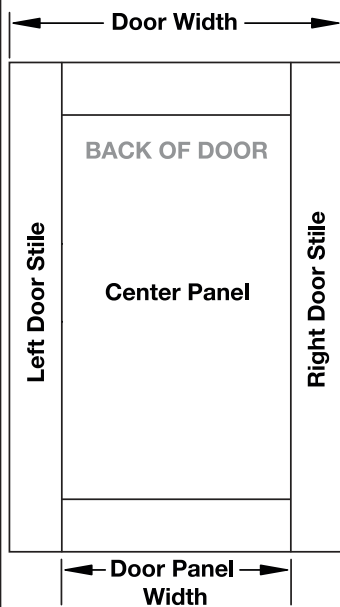

Fig. 8

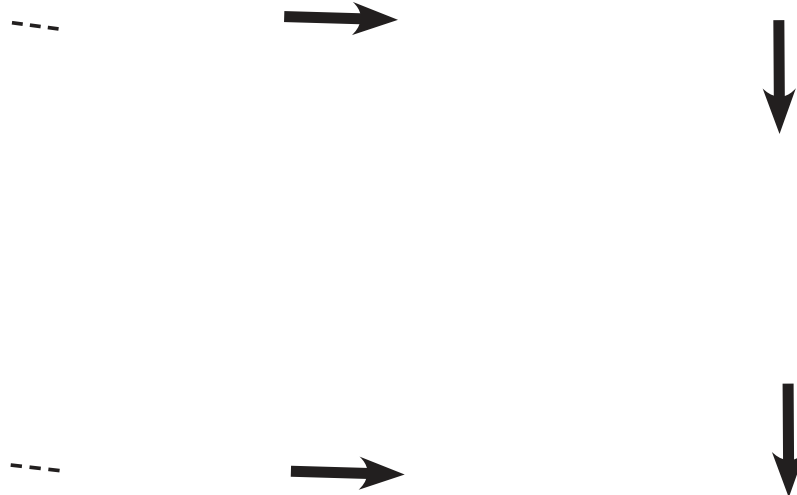
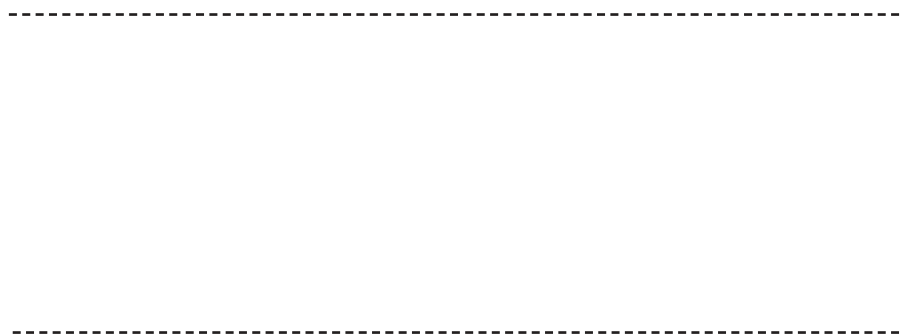

Fig. 9



- B. Press the cabinet door against the door brackets firmly to ensure the door adheres to the double sided tape.
- C. Grasp the bottom of the cabinet door and slowly open the sliding assembly until you have easy access to the door brackets.
- D. Install #6 x 5/8" mounting screws in the center of each of the four horizontal slots shown. **(Fig. 10A, 10B and 10C)**
- E. Ensure your door is centered by closing the unit into the cabinet.

6. Adjust Door Angle

- A. Using the door, push trash unit back into the cabinet until it stops. If there is a gap between the top of the door and the cabinet, adjust the door bracket by loosening the tilt adjusting screw and pivot the the door to the desired position. Ensure door is in the desired position, then install a second locking screw in location shown. **(Fig. 11)**
- B. Place waste bin(s) in chassis. Installation is now complete.

