

2. Trim the flange on the seal strips so that there is enough clearance for the door to roll without the seal strips hitting against the rollers or door stopper. /

2. Recorte la brida de las tiras de sellado de manera que haya suficiente espacio para que la puerta ruede sin que las tiras de sellado toquen los rodillos o el tope de la puerta. /

2. Coupez la bride des bandes d'étanchéité de manière à laisser suffisamment de place pour que la porte puisse rouler sans que les bandes d'étanchéité ne touchent les rouleaux ou le butoir de la porte.

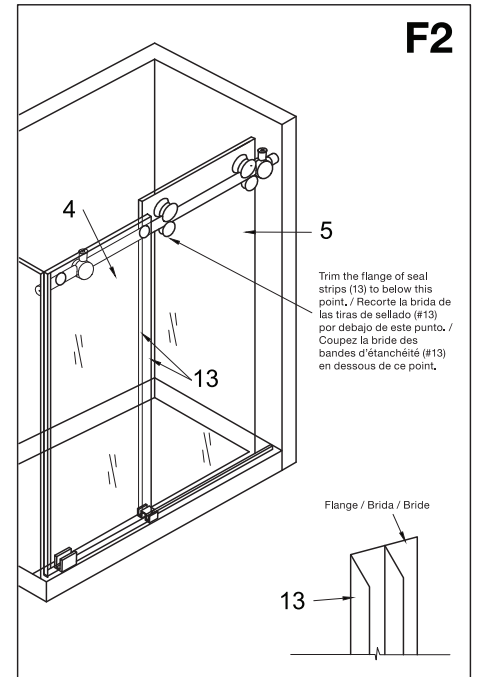

F. Applying the silicone / Aplicación de la silicona / Application de la silicone

1. Apply clear silicone caulking along the wall and floor of the shower enclosure interior and along the fixed panel and threshold of the shower enclosure interior. /

1. Aplique sellador de silicona transparente a lo largo de la pared y el piso del interior de la cabina de ducha y a lo largo del panel fijo y el umbral del interior de la cabina de ducha. /

1. Appliquez un scellant au silicone transparent le long du mur et du sol de l'intérieur de la cabine de douche et du panneau fixe et du seuil de l'intérieur de la cabine de douche.

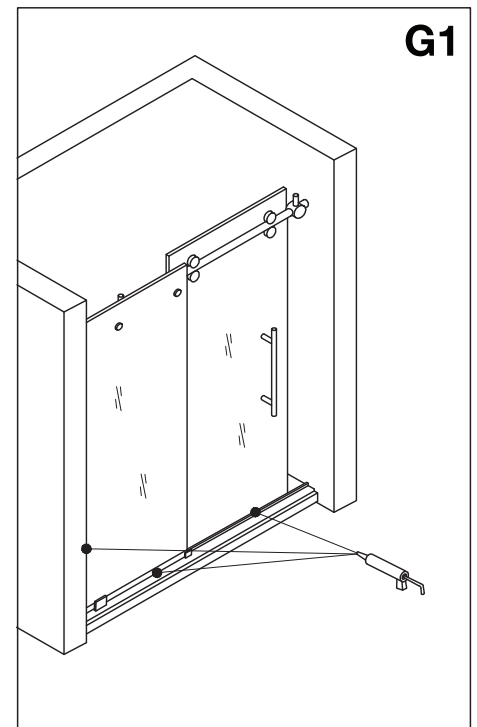

Roller adjustments to accommodate out of square openings / Ajuste de los rodillos para adaptarlos a aberturas fuera de escuadra / Ajustements des rouleaux pour accueillir les ouvertures hors carré

NOTE / NOTA / REMARQUE

There is a 3/8" adjustment in the roller to use in the case that your walls are not plumb and level. Using an allen key, you will be able to adjust the roller to accommodate for the variance. / Los rodillos tienen un ajuste de 3/8" para el caso de que sus paredes no estén a plomo y niveladas. Podrá ajustar el rodillo en función de la variación utilizando una llave Allen. / Il y a un réglage de 3/8" dans le rouleau, à utiliser dans le cas où vos murs ne sont pas d'aplomb et à niveau. En utilisant une clé Allen, vous pourrez ajuster le rouleau en fonction de la variation.

- Loosen the hex screw to allow for movement. Then place the allen key in the small hex hole as shown and roll it to the right or left to make the adjustment. [See Fig.1]
 - Fig. 1A displays the 3 different positions.
 - If your walls are plumb and level, follow the configuration in Fig. 2.
 - If your wall is off on the top, the rollers should be adjusted as shown in Fig. 3.
 - If your wall is off on the bottom, the rollers should be adjusted as shown in Fig. 4.
- Afloje el tornillo hexagonal para permitir el movimiento. Luego coloque la llave Allen en el pequeño orificio hexagonal, como se muestra en la figura, y gírela hacia la derecha o hacia la izquierda para realizar el ajuste. [Ver Fig. 1]
 - La Fig. 1A muestra las 3 posiciones diferentes.
 - Si sus paredes están a plomo y niveladas, siga la configuración en la Fig. 2.
 - Si su pared está fuera de plomo en la parte superior, los rodillos deberán ajustarse como se muestra en la Fig. 3.
 - Si su pared está fuera de plomo en la parte inferior, los rodillos deberán ajustarse como se muestra en la Fig. 4.
- Desserrez la vis hexagonale pour permettre le mouvement. Placez ensuite la clé Allen dans le petit trou hexagonal comme indiqué et faites-la rouler vers la droite ou vers la gauche pour effectuer le réglage. [Voir Fig. 1]
 - La Fig. 1A montre les 3 positions différentes.
 - Si vos murs sont d'aplomb et à niveau, suivez la configuration de la Fig. 2.
 - Si la déviation de votre mur est sur le haut, les rouleaux doivent être ajustés comme indiqué dans la Fig. 3.
 - Si la déviation de votre mur est sur le bas, les rouleaux doivent être ajustés comme indiqué dans la Fig. 4.

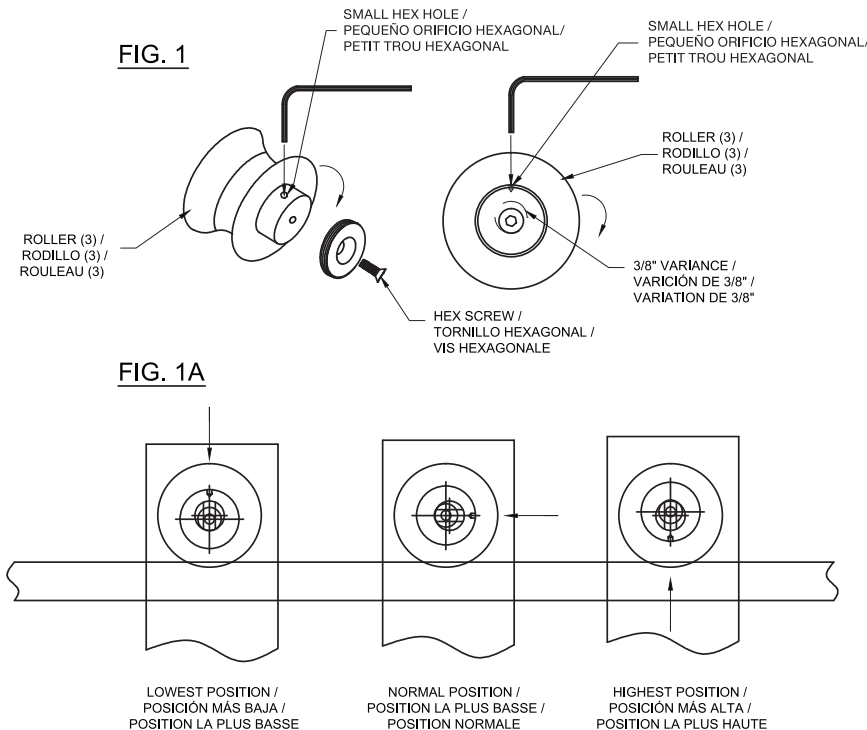

NOTE: These adjustments are approximate. You may need to adjust the direction of the small hex hole to meet your needs. / NOTA: Estos ajustes son aproximados. Es posible que deba ajustar la dirección del pequeño orificio hexagonal para adecuarlo a sus necesidades. / REMARQUE: Ces ajustements sont approximatifs. Vous devrez peut-être ajuster la direction du petit trou hexagonal pour répondre à vos besoins.

Roller adjustments to accommodate out of square openings / Ajuste de los rodillos para adaptarlos a aberturas fuera de escuadra / Ajustements des rouleaux pour accueillir les ouvertures hors carré

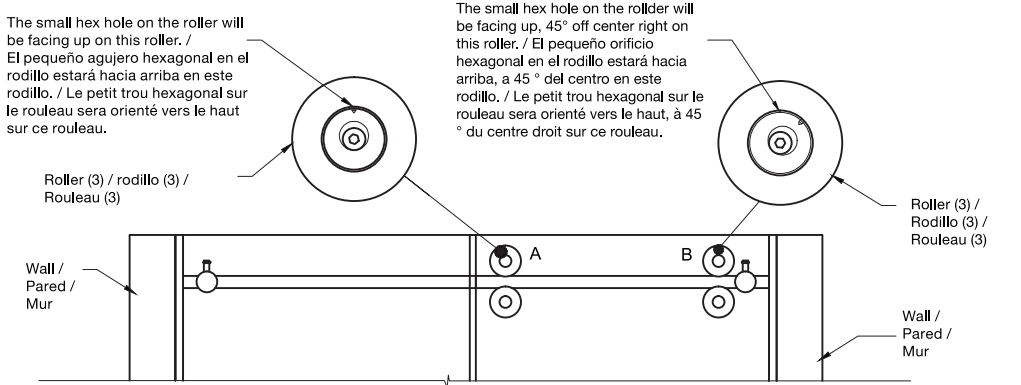

Straight Walls / Paredes rectas / Murs Droits	
Roller "A" Small Hex Hole Direction / Dirección del pequeño orificio hexagonal del rodillo "A"/ Rouleau « a » direction du petit trou hexagonal	Roller "B" Small Hex Hole Direction / Dirección del pequeño orificio hexagonal del rodillo "B"/ Rouleau « b » direction du petit trou hexagonal
Up / Arriba / Vers le haut	Up, 45° right / Arriba, 45° hacia la derecha / Vers le haut, 45° à droite

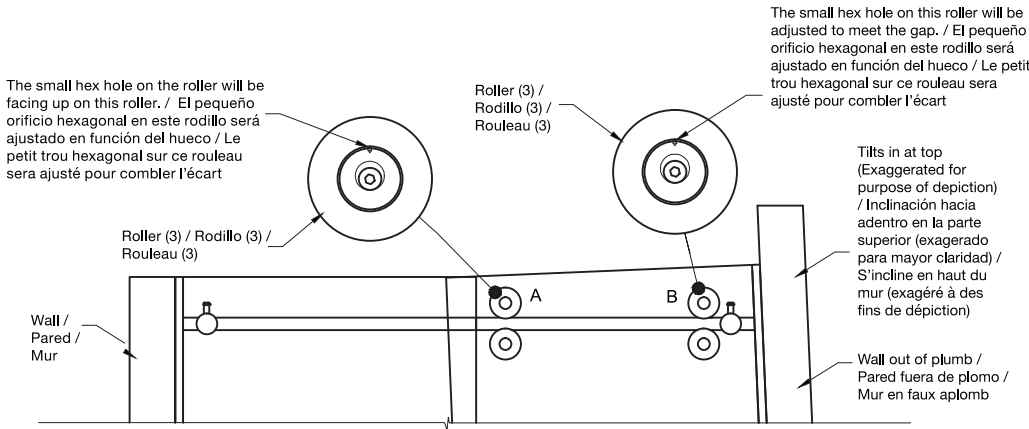

Top Angled Wall / Pared en ángulo superior / Mur d'angle supérieur	
Roller "A" Small Hex Hole Direction / Dirección del pequeño orificio hexagonal del rodillo "A"/ Rouleau « a » direction du petit trou hexagonal	Roller "B" Small Hex Hole Direction / Dirección del pequeño orificio hexagonal del rodillo "B"/ Rouleau « b » direction du petit trou hexagonal
Up / Arriba / Vers le haut	Adjusted As Needed / Ajustar según sea necesario / Ajustez au besoin

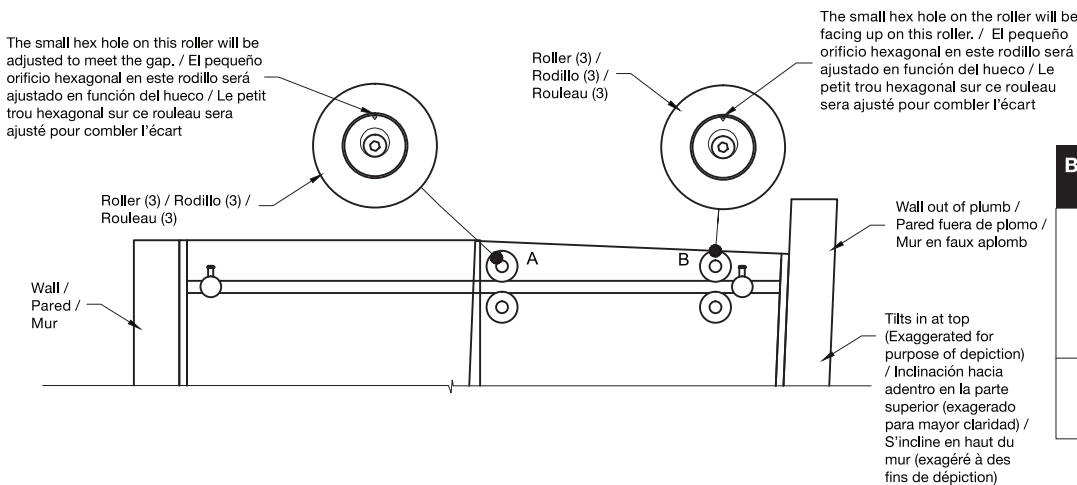

Bottom Angled Wall / Pared en ángulo inferior / Mur d'angle inférieur	
Roller "A" Small Hex Hole Direction / Dirección del pequeño orificio hexagonal del rodillo "A"/ Rouleau « a » direction du petit trou hexagonal	Roller "B" Small Hex Hole Direction / Dirección del pequeño orificio hexagonal del rodillo "B"/ Rouleau « b » direction du petit trou hexagonal
Up / Arriba / Vers le haut	Adjusted As Needed / Ajustar según sea necesario / Ajustez au besoin

Modern faucets and showers consist of very different materials to comply with the needs of the market with regard to design and functionality. To avoid damage and reclamations, it is necessary to consider certain criteria when cleaning. Be sure to avoid using abrasive materials while cleaning VIGO products.

REGISTER YOUR PRODUCT

CLEANING INSTRUCTIONS FOR FAUCETS AND SHOWERS

Please follow the instructions on your cleaning materials. In addition, pay attention to the following points:

- Clean the faucets and showers as needed and when required.
- The amount of cleaning product needed and the time the cleaner needs in order for effective cleaning to take place should be adjusted according to products; cleaning product should not be left on VIGO product longer than necessary.
- Clean regularly to prevent calcification.
- When using spray cleaner, spray first onto a cloth or sponge - never directly spray onto the sanitary tapware as drops could enter openings and gaps and cause damage.
- After cleaning, rinse thoroughly with clean water to remove any cleaner residue.
- Recommended cleaning solution for hard water and soap scum is to use 50/50 water and vinegar solution.



NEVER SPRAY
DIRECTLY
ON TAPWARE



SPRAY ONTO
SPONGE/ CLOTH



CLEAN
REGULARLY



RINSE THOROUGHLY
WITH CLEAN WATER

CLEANING MATERIAL FOR FAUCETS AND SHOWERS

Acids are necessary ingredients of cleaning materials for removing lime, however, please pay attention to the following points when cleaning faucets and showers:

- Only use cleaning materials that are explicitly provided for this type of application.
- Never use cleaning materials that contain hydrochloric, formic or acetic acid, as they cause considerable damage.
- Phosphoric acid is also restricted as it can cause damage to the finish.
- Never mix any cleaning material with another.
- Never use cleaning materials that have an abrasive effect, such powdered and industrial cleansers, scouring pads or micro fiber cloths.

~~Hydrochloric~~

~~Formic~~

~~Acetic Acid~~

~~Phosphoric~~